

# CORTEX EBC

## USER MANUAL

VERSION 6.3.7 | REVISION A

# TABLE OF CONTENTS

<b>INSTALLATION</b>	<b>4</b>
Included Parts	5
Complete Kit	5
Base Kit	6
Wiring	7
General Wiring Guidelines	7
Wiring Harness Pinout and Signal Descriptions	8
Compatible RPM signals	9
Compatible Vehicle Speed Signals	10
Compatible General-Purpose Input Signals	11
Connecting GM/Continental Flex-Fuel Sensor To GPI	12
Connecting External Buttons to Inputs	13
Auxiliary Output Wiring	19
Manifold Pressure Reference	20
Boost Control Solenoid Plumbing – Single Turbo	21
3-Port Internal Wastegate/Actuator Configuration	21
3-Port External Wastegate Configuration 1	22
3-Port External Wastegate Configuration 2	23
3-Port External Wastegate Compressed Air Configuration	24
4-Port External Wastegate Configuration	25
Boost Control Solenoid Plumbing – Twin Turbo	26
3-Port Internal Wastegate/Actuator Configuration	26
3-Port External Wastegate Configuration 1	27
3-Port External Wastegate Configuration 2	28
3-Port External Wastegate Compressed Air Configuration	29
4-Port External Wastegate Configuration	30
<b>DEVICE OPERATION</b>	<b>31</b>
Top Button Function Mode	32
Menu System	33
Changing Boost Control Profile	34
Enabling Internal Logger	35
Enabling Auxiliary Outputs	36
Changing Top Button Function Mode	37
Changing Gauge Data	39
Changing Boost Units	41
Changing Display Brightness	42

- SOFTWARE .....43**
- USB Connection ..... 44
- Viewing and Editing Boost Configuration Files ..... 45
  - Editing Tables ..... 46
  - Profile Copy/Paste..... 47
  - Gear-Based Dialog Copy/Paste..... 47
- Data Logging ..... 48
  - Data Acquisition ..... 48
  - Internal Logger ..... 49
- INPUT SIGNAL CONFIGURATION.....50**
- RPM Input..... 51
  - RPM Calibration Procedure ..... 52
- Speed Input ..... 53
  - Speed Calibration Procedure ..... 54
- General-Purpose Input ..... 57
  - GPI Calibration Procedure ..... 58
- Gear Detection Tab..... 59
  - Gear Detection Calibration Procedure ..... 60
- BOOST CONTROL.....67**
- Boost Control Settings ..... 68
  - Configuration ..... 68
  - Open-Loop..... 75
  - Closed-Loop..... 80
  - Launch ..... 86
  - Fail-Safes ..... 91
- Additional Notes for Boost by RPM ..... 97
- Additional Notes for Boost by Speed..... 97
- Additional Notes for Boost by Time ..... 97
- Additional Notes for Compressed Air Boost Control ..... 97
- AUXILIARY OUTPUTS .....98**
- Output Configuration ..... 99
  - Primary Output Activation Criteria ..... 99
  - Alternate Output Functions ..... 102
  - PWM Configuration..... 102

## INSTALLATION

It is strongly recommended that the Cortex EBC device be installed by an automotive professional. Improper installation can result in damage to both your vehicle and the Cortex EBC device.

The Cortex EBC should be mounted inside the vehicle to protect it from dirt, moisture, excessive heat, and other environmental elements. The device is not waterproof, and exposure to moisture can cause damage.

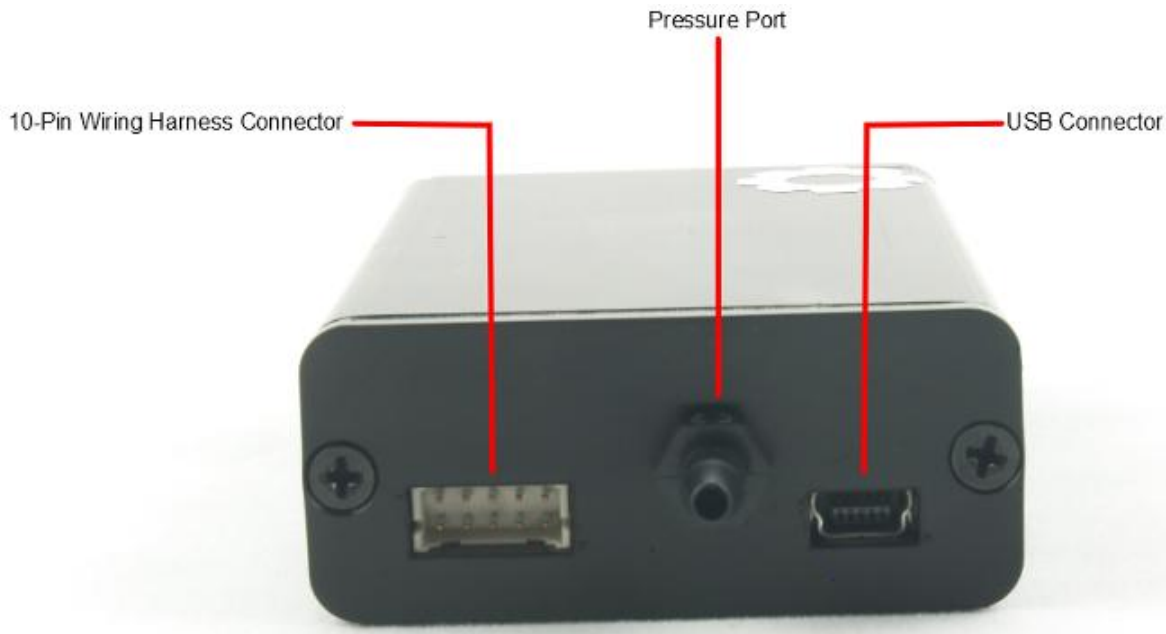

**Cortex EBC installation requires the completion of the following steps:**

- [Connect the Cortex EBC wiring harness to the appropriate signals in your vehicle's electrical system.](#)
- [Connect the Cortex EBC device to a suitable intake manifold pressure reference.](#)
- [Connect the boost control solenoid to your vehicle's turbocharger\(s\) and wastegate\(s\).](#)

**After installation, you will need to create a vehicle configuration file for your application.**

- [Using the Cortex Config Software](#)
- [RPM Input Configuration](#)
- [Speed Input Configuration](#)
- [General-Purpose Input Configuration](#)
- [Gear Detection Configuration](#)

**With installation and vehicle configuration complete, you can begin adjusting boost.**

- [How the Cortex EBC Controls Boost](#)
- [Profile Configuration](#)
- [Open-Loop Boost Control](#)
- [Closed-Loop Boost Control](#)
- [Boost Control Fail-Safes](#)

INCLUDED PARTS

COMPLETE KIT

 <p>CORTEX EBC DEVICE</p>		 <p>3-PORT OR 4-PORT BCS</p>	
 <p>USB MINI-B CABLE</p>	 <p>CORTEX EBC WIRING HARNESS</p>	 <p>FUSE HOLDER AND 2 AMP FUSE</p>	 <p>ZIP TIES QTY 12</p>
 <p>3/16" SILICONE VACUUM HOSE 6 FEET</p>	 <p>1/8" SILICONE VACUUM HOSE 10 FEET</p>	 <p>3/16" HOSE BARB QTY 3</p>	 <p>3/16" TO 1/8" HOSE REDUCER QTY 1</p>
 <p>3/16" HOSE TEE QTY 2</p>	 <p>1/8" HOSE TEE QTY 1</p>		



## WIRING

Wiring the Cortex EBC involves connecting between two and seven electrical signals to the wiring harness, depending on your specific application. Input signals to the Cortex EBC can originate from factory wiring, signal conditioning interfaces, aftermarket sensors, or external buttons. Output signals from the Cortex EBC may connect to devices such as other control modules, solid-state relays, or indicator lights.

When splicing into existing sensor signals, it is recommended to use solder and heat shrink for secure and reliable connections. If soldering is not feasible, [Posi-Tap](#) connectors are a good alternative. The “T Tap” or “Solderless Quick Splice” connectors from local parts stores are unreliable and should not be used under any circumstances.

**Note:** For all boost-by-gear applications, engine speed and vehicle speed signals are required. The vehicle speed signal must come from a “driven” source for the gear detection to function correctly. For example, on a rear-wheel-drive (RWD) vehicle, you cannot use a front-wheel speed signal.

**WARNING: IMPROPER ELECTRICAL CONNECTIONS CAN RESULT IN UNPREDICTABLE BEHAVIOR AND DAMAGE TO THE CORTEX EBC DEVICE OR THE VEHICLE'S ELECTRICAL SYSTEM.**

**WARNING: THE POWER INPUT ON THE CORTEX EBC WIRING HARNESS (PIN 3) MUST BE CONNECTED TO A FUSED POWER SOURCE WITH 5A OR SMALLER FUSE. FAILURE TO USE A FUSED POWER SOURCE MAY RESULT IN DAMAGE TO THE CORTEX EBC DEVICE.**

**WARNING: DO NOT CONNECT THE RPM INPUT ON THE CORTEX EBC WIRING HARNESS (PIN 8) TO THE SECONDARY / HIGH VOLTAGE SIDE OF AN IGNITION COIL.**

---

### GENERAL WIRING GUIDELINES

1. Disconnect the negative battery terminal.
2. Place the 10-pin connector of the Cortex EBC wiring harness near the Cortex EBC device.
3. Connect a 12V switched/fused power source and chassis ground to the Cortex EBC wiring harness.
4. Connect appropriate signals to the RPM, speed, and general-purpose inputs on the Cortex EBC wiring harness.
5. If applicable, connect output 1 and output 2 on the Cortex EBC wiring harness to the devices they will be controlling.
6. Route the solenoid sub-harness into the engine bay and plug the 2-pin connector into the boost control solenoid (complete kits) or boost control solenoid pigtail (base kits).
7. Plug the 10-pin wiring harness connector into the back of the Cortex EBC device. The harness should be plugged in such that the purple, red, orange, and black wires are towards the top of the Cortex EBC device.

See [this page](#) on our website for application-specific wiring guides.

## WIRING HARNESS PINOUT AND SIGNAL DESCRIPTIONS

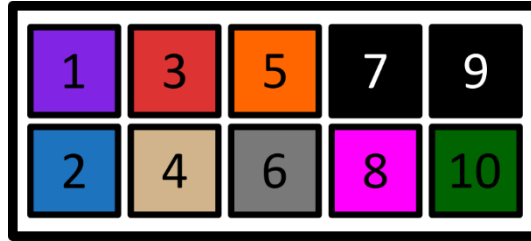

Wire Side of 10-Pin Connector with Pins Labeled

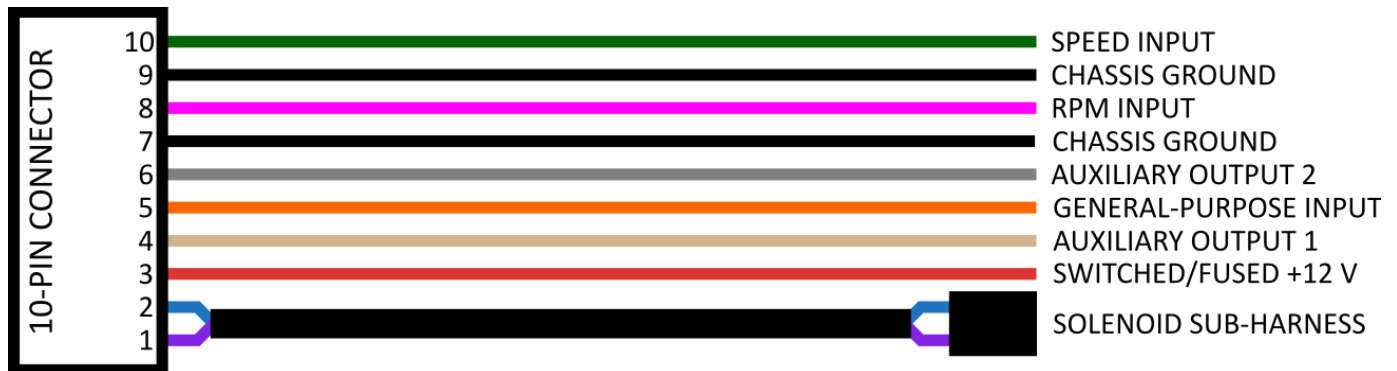

Wiring Harness Diagram

PIN	COLOR	DESCRIPTION	SIGNAL TYPE	CONNECTION DETAILS
1	PURPLE	Boost Control Solenoid Power	Power Output	Plug the 2-pin connector into the boost control solenoid or solenoid pigtail.*
2	BLUE	Boost Control Solenoid Trigger	Switch to Ground PWM Output	Plug the 2-pin connector into the boost control solenoid or solenoid pigtail.*
3	RED	Switched 12V	Power Input	Connect to switched and fused 12 V power source (fuse rating 5 A or less).
4	TAN	Output 1	Switch to Ground PWM Output	Resistive loads only. Cover end if unused. <b>Max Current: 200 mA.</b>
5	ORANGE	General-Purpose Input	Analog or Digital Input	Connect to an analog or digital sensor with linear output, launch button, transbrake bump button, or scramble button. Connect to chassis ground if unused. <b>Min Voltage: 0 V. Max Voltage 16 V.</b>
6	GRAY	Output 2	Switch to Ground PWM Output	Resistive loads only. Cover end if unused. <b>Max Current: 200 mA.</b>
7	BLACK	Chassis Ground	Ground Input	Connect directly to clean chassis ground (may not be present on older wiring harnesses).
8	PINK	RPM Input	Digital Input	Connect to an engine speed signal, launch button, transbrake bump button, or scramble button. Connect to chassis ground if unused.
9	BLACK	Chassis Ground	Ground Input	Connect directly to clean chassis ground.
10	GREEN	Speed Input	Digital Input	Connect to a vehicle speed signal, launch button, transbrake bump button, or scramble button. Connect to chassis ground if unused.

\*Solenoids are not polarized, and either pigtail wire can be connected to either wire on the solenoid.

---

## COMPATIBLE RPM SIGNALS

Engine speed signals compatible with the Cortex EBC are typically available in the factory wiring for most applications. However, older vehicles may require additional hardware to convert a VR sensor signal into a waveform that the Cortex EBC can detect.

The following engine speed signal types can be connected to the Cortex EBC (in order of preference):

- Tach signal from ECU/ECM/PCM or gauge cluster
- RPM output from [CAN Bus Wheel Speed and RPM Interface for Mustang / F-150](#)
- RPM output from [CB-2 CAN Bus Speed and RPM Interface](#)
- Cam or crank position sensor
  - The Cortex EBC can interpret any trigger wheel pattern with 60 teeth or less (tooth gaps will not cause any issues).
  - All 3-wire Hall sensors can be connected to the controller. An external pull-up resistor may be required if the sensor is connected to the Cortex EBC only.
  - Some 2-wire VR sensors can be connected directly to the controller without any additional hardware, but using a VR sensor interface such as the [Speed Sensor Adapter V2](#) or [VR To Hall Sensor Converter](#) is strongly recommended.
- Ignition coil trigger signal from ECU/ECM/PCM or ground (-) terminal on the primary (low voltage) side of an ignition coil
  - Electrical noise on some applications may prevent the Cortex EBC from accurately calculating RPM.
- Port fuel injector trigger signal from ECU/ECM/PCM (not compatible with gasoline direct injection)
  - Electrical noise on some applications may prevent the Cortex EBC from accurately calculating RPM.

See [this section](#) to learn how to configure the RPM input on the Cortex EBC.

---

## COMPATIBLE VEHICLE SPEED SIGNALS

The Cortex EBC is compatible with vehicle speed signals that generate up to 192,000 pulses per mile. In most vehicles manufactured between 1988 and 2007, compatible signals can typically be found at the transmission, differential, ECU/ECM/PCM, or gauge cluster. However, older vehicles may require additional hardware to convert a VR sensor signal into a waveform that the Cortex EBC can detect.

For many vehicles manufactured after 2007, additional hardware is necessary to extract a vehicle speed signal from the CAN bus system or an ABS wheel speed sensor.

For optimal performance in boost-by-speed applications, the vehicle speed signal should come from an "undriven" source, e.g., the front wheels on a rear-wheel-drive (RWD) vehicle or the rear wheels on a front-wheel-drive (FWD) vehicle.

The following vehicle speed signal types can be connected to the Cortex EBC:

- Speed pulse output from ECU/ECM/PCM or gauge cluster
- Speed pulse output from [CAN Bus Wheel Speed and RPM Interface for Mustang / F-150](#)
- Speed pulse output from [CB-2 CAN Bus Speed and RPM Interface](#)
- Transmission output shaft speed sensor or differential speed sensor
  - All 3-wire Hall sensors can be connected to the controller. An external pull-up resistor may be required if the sensor is connected to the Cortex EBC only.
  - Some 2-wire VR sensors can be connected directly to the controller without any additional hardware, but using a VR sensor interface such as the [Speed Sensor Adapter V2](#) or [VR To Hall Sensor Converter](#) is strongly recommended.
- Wheel speed sensors
  - Active (2-wire Hall) ABS wheel speed sensors require the use of the [Speed Sensor Adapter V2](#). Most active sensors are compatible with this device. 2011+ Ford Mustang and F-150 applications can alternatively use the [Wheel Speed Sensor Adapter for Mustang / F-150](#).
  - Some passive (VR) ABS wheel speed sensors can be connected directly to the controller without any additional hardware, but using a VR sensor interface such as the [Speed Sensor Adapter V2](#) or [VR To Hall Sensor Converter](#) is strongly recommended.
  - If you have installed an aftermarket 3-wire Hall sensor to read wheel speed no additional modules are required, but your sensor may require an external "pull-up resistor" to generate a signal. Consult your sensor manufacturer for more information.

See [this section](#) to learn how to configure the speed input on the Cortex EBC.

---

## COMPATIBLE GENERAL-PURPOSE INPUT SIGNALS

The general-purpose input is compatible with a wide range of analog (voltage) and digital (frequency) sensors that provide a linear output. A linear output means that when you plot the raw sensor output (volts or Hz) against the scaled sensor output, the result is a straight line, as illustrated in the chart below.

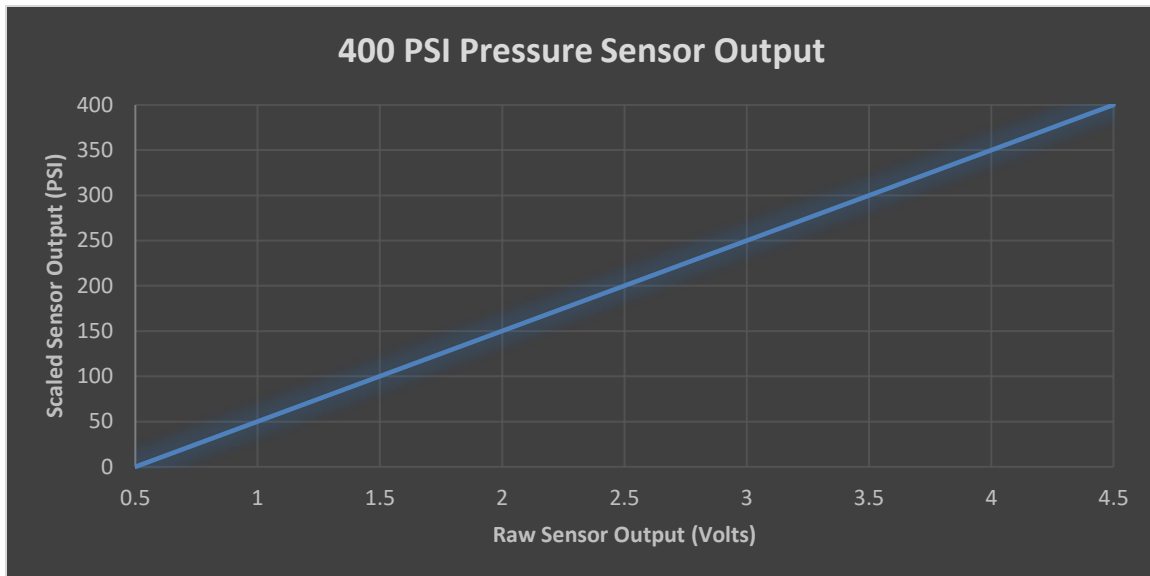

The general-purpose input can be used for various applications, such as monitoring throttle position, ethanol content, air-fuel ratio from a WBO2 controller, turbo speed, or water/methanol injection pressure or flow. Most temperature sensors produce a nonlinear output and cannot be interpreted by the Cortex EBC.

**Min Voltage:** 0 V

**Max Voltage:** 16 V

**Max Frequency:** 5,000 Hz

**Logic Threshold:** 2.5 V

See [this section](#) to learn how to configure the general-purpose input on the Cortex EBC.

## CONNECTING GM/CONTINENTAL FLEX-FUEL SENSOR TO GPI

The output from GM/Continental flex-fuel sensors can be connected directly to the general-purpose input on the Cortex EBC wiring harness if your vehicle came equipped with a factory sensor, or if your sensor is already wired to your ECU/ECM/PCM or another device.

If the Cortex EBC will be the only device connected to the flex-fuel sensor, use the diagram below when installing your sensor. In this configuration, the Cortex EBC requires a pull-up resistor between the sensor's power and output wires to properly detect the sensor signal.

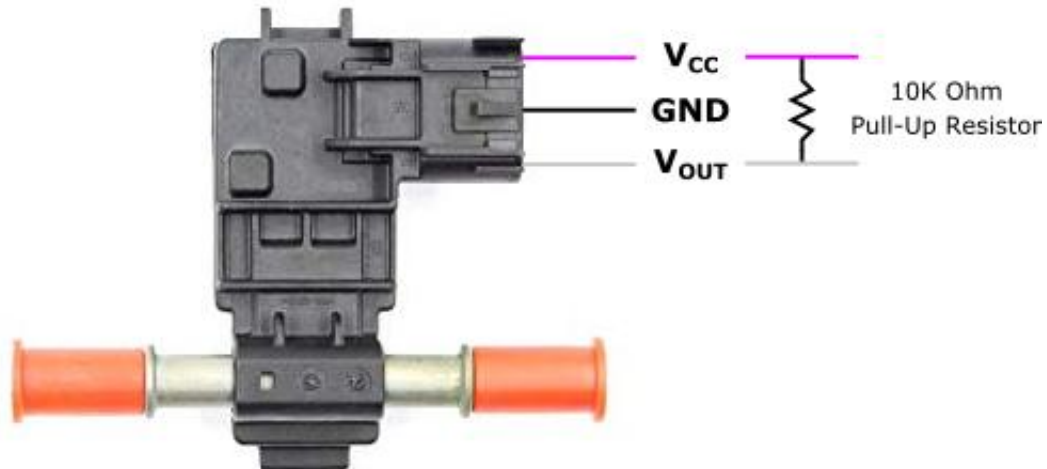

See [this section](#) to learn how to configure the general-purpose input on the Cortex EBC.

---

## CONNECTING EXTERNAL BUTTONS TO INPUTS

In general, connecting an external button to the Cortex EBC will require the implementation of a simple “pull-up circuit” that requires an external resistor. This circuit is typically used for boost scramble control or transbrake bump control activation.

**GERNARL-PURPOSE INPUT WARNING:** When using the general-purpose input for launch boost control activation, the signal cannot come directly from a transbrake solenoid unless the transbrake bump function is being utilized in conjunction with a [Transbrake Bump Driver](#). If you do not plan to use the transbrake bump functionality available on the Cortex EBC, then a few additional components or a diode-protected relay will be required. See the diagrams on the following pages for additional information.

---

### BOOST SCRAMBLE OR TRANSBRAKE BUMP INPUT FROM EXTERNAL BUTTON

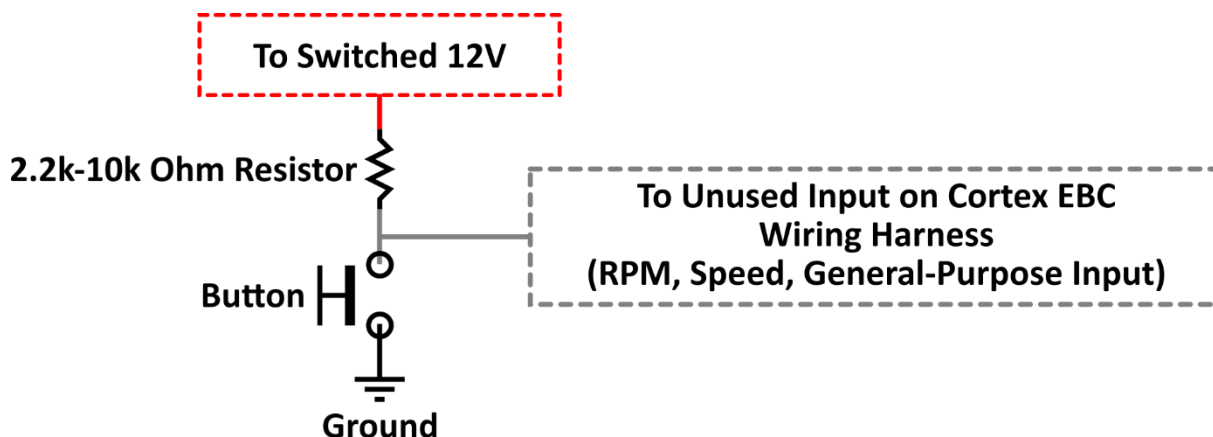

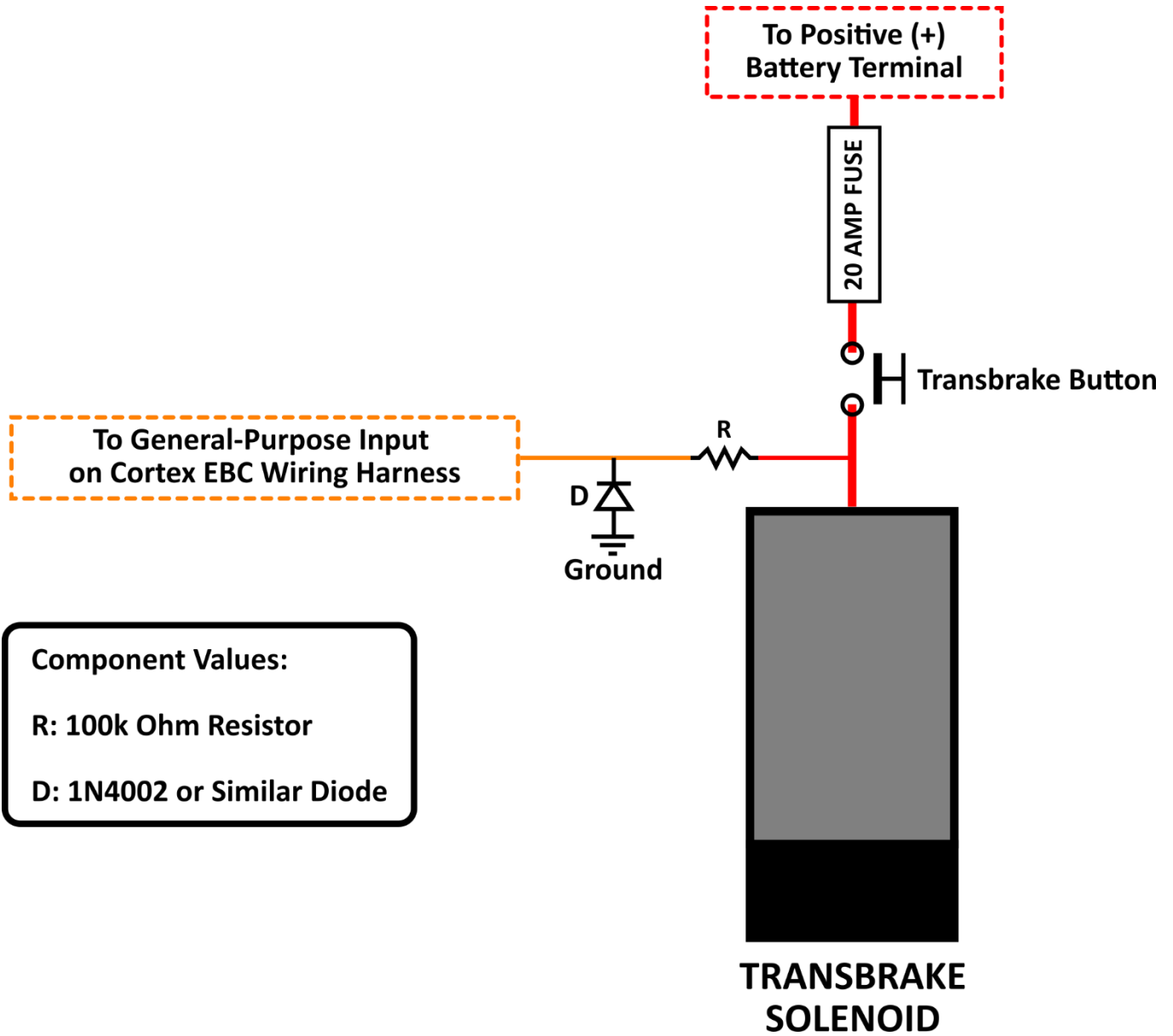

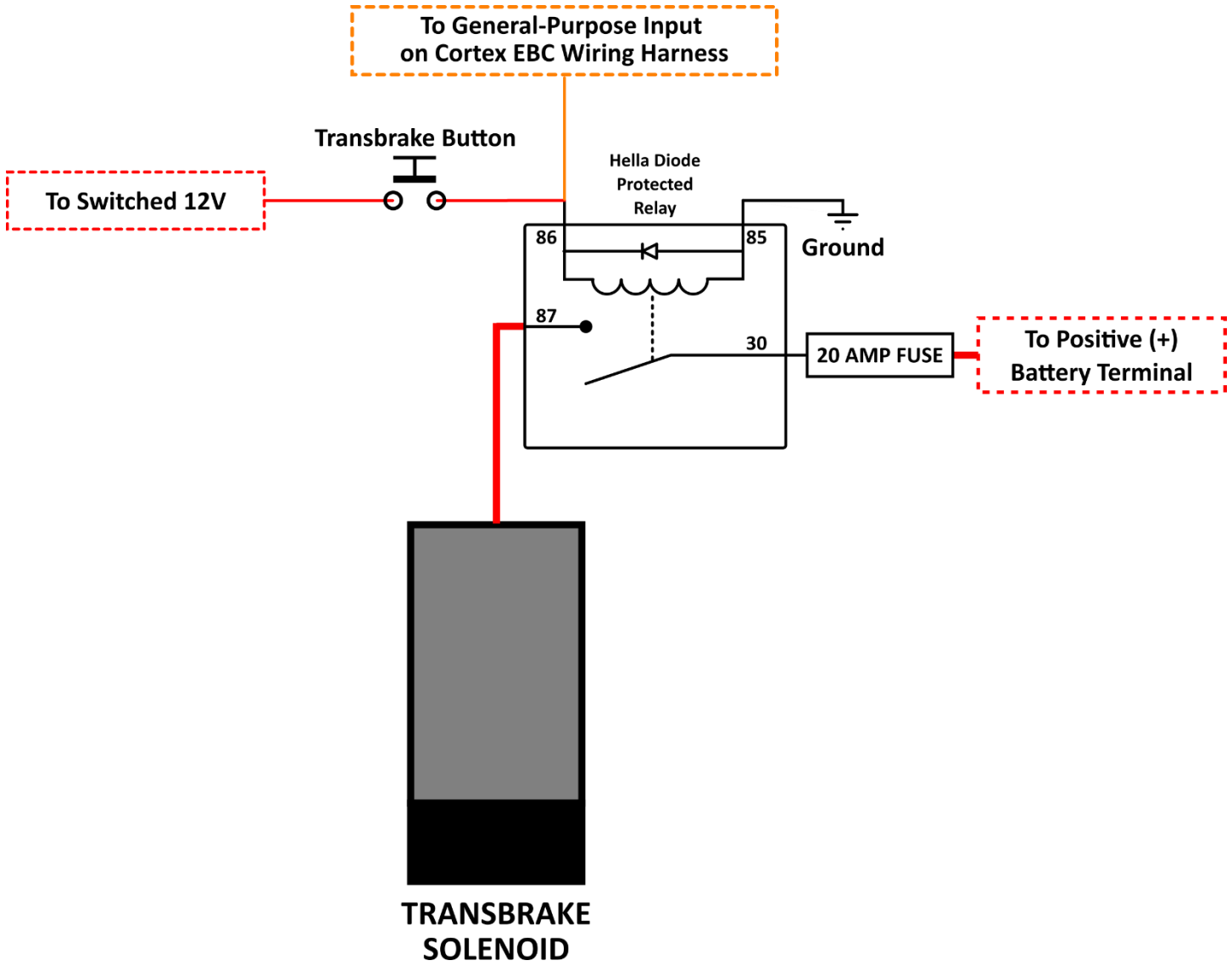

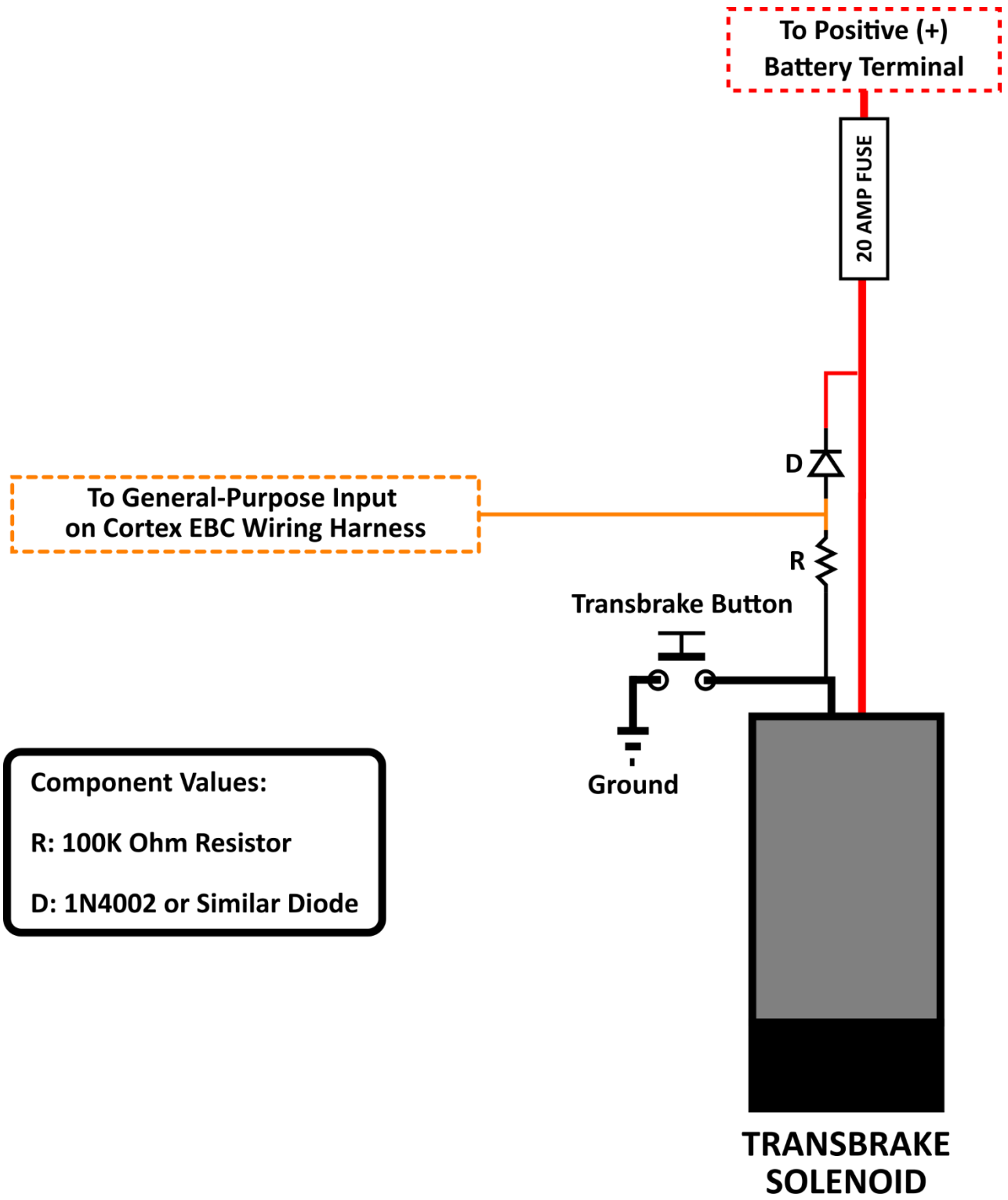

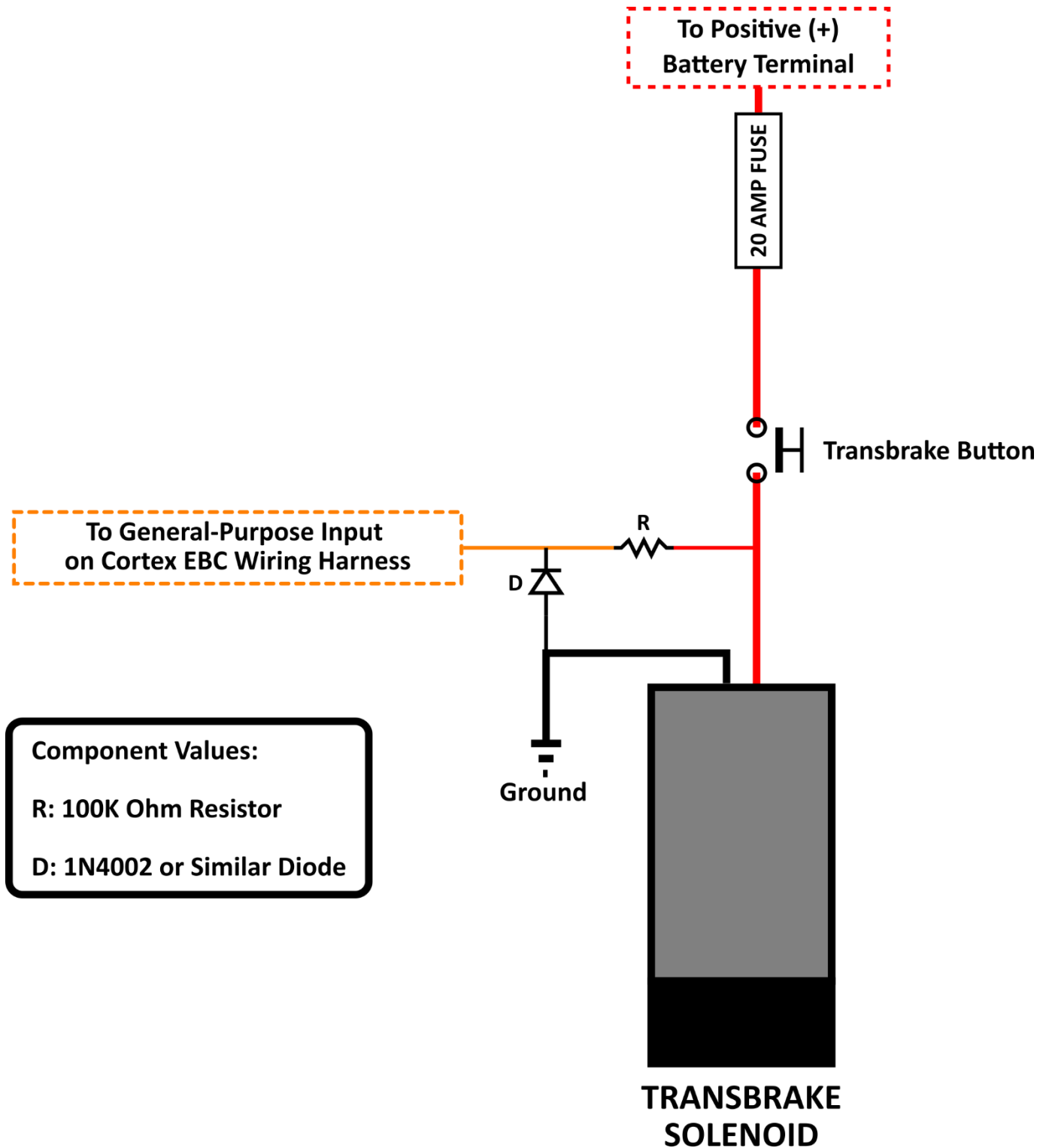

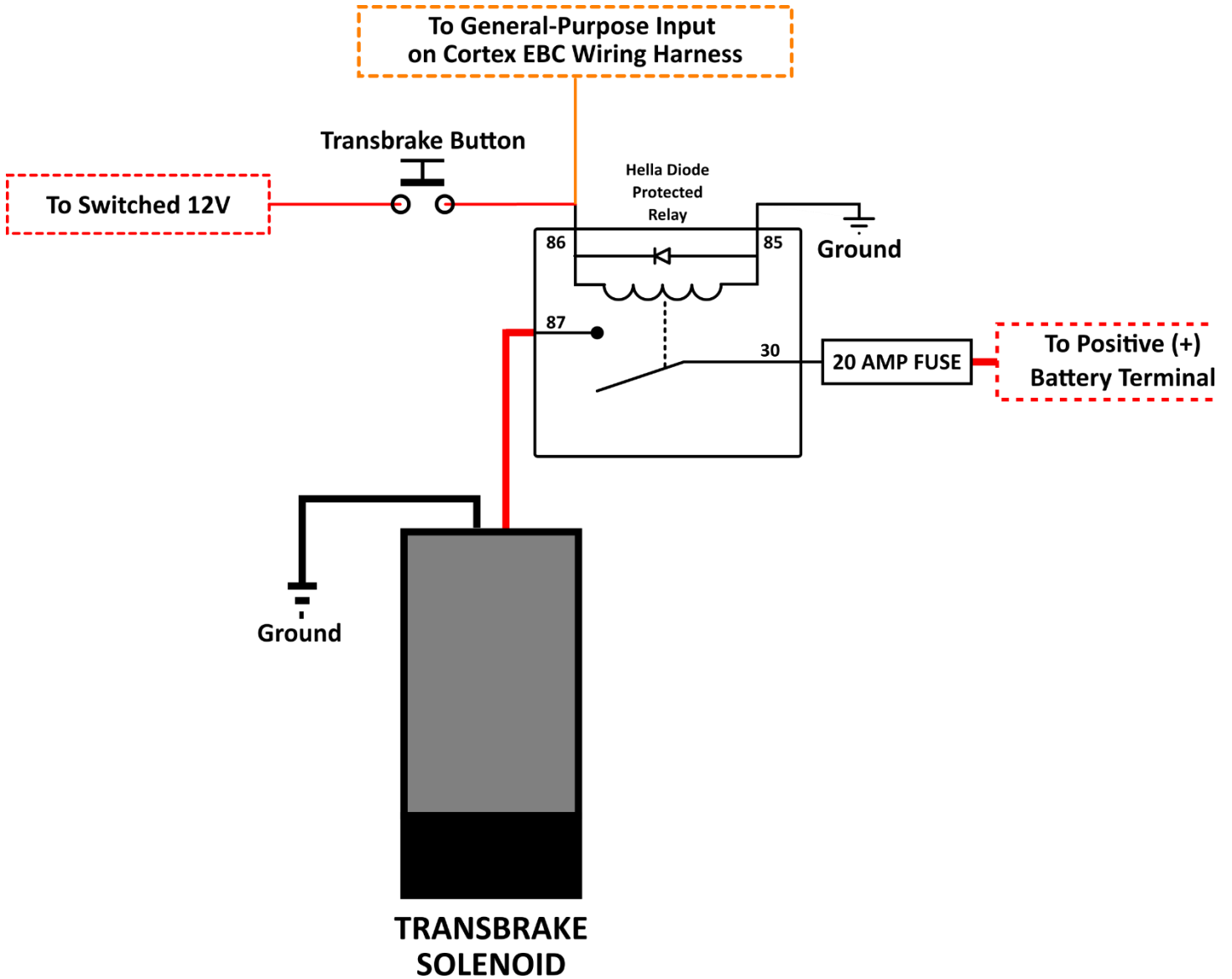

**The outputs are ground-side switches. When an output is activated, it will switch from an open circuit (floating state) to ground.**

**The outputs can control resistive loads with a current draw of 200 mA or less (LEDs, inputs on SSRs, or inputs on other control devices).**

**The outputs cannot control standard electromechanical relays, solenoids, pumps, or motors without the use of additional electrical components to protect the Cortex EBC device.**

The auxiliary outputs are known to be compatible with the following devices:

- Digital inputs on other control devices.
- Ground terminal on 12V compatible LED or incandescent bulb.
- Terminal 85 of Hella 933791091 or 007494041 Diode-Protected Relays
- Terminal 86 of Hella H41773001 / 931773987 Solid-State Relay
- Trigger wire of NOS 15620NOS Solid State Relay
- The control input (purple wire) on any SIRHC Labs Output Driver

Other diode-protected and solid-state relays may be compatible with the Cortex EBC. Please contact [info@sirhclabs.com](mailto:info@sirhclabs.com) to find out if your relay can be controlled by the Cortex EBC.

**See [this section](#) to learn how to enable the auxiliary outputs.**

**See [this section](#) for information on auxiliary output configuration.**

## MANIFOLD PRESSURE REFERENCE

To monitor and control boost pressure effectively, the pressure port on the back of the Cortex EBC device must be connected to a pressure reference on the intake manifold, located downstream of the throttle body. While the Cortex EBC cannot precisely measure vacuum pressure, it can detect the presence of engine vacuum. Using a pressure reference that is not located on the intake manifold may lead to unpredictable boost control performance.

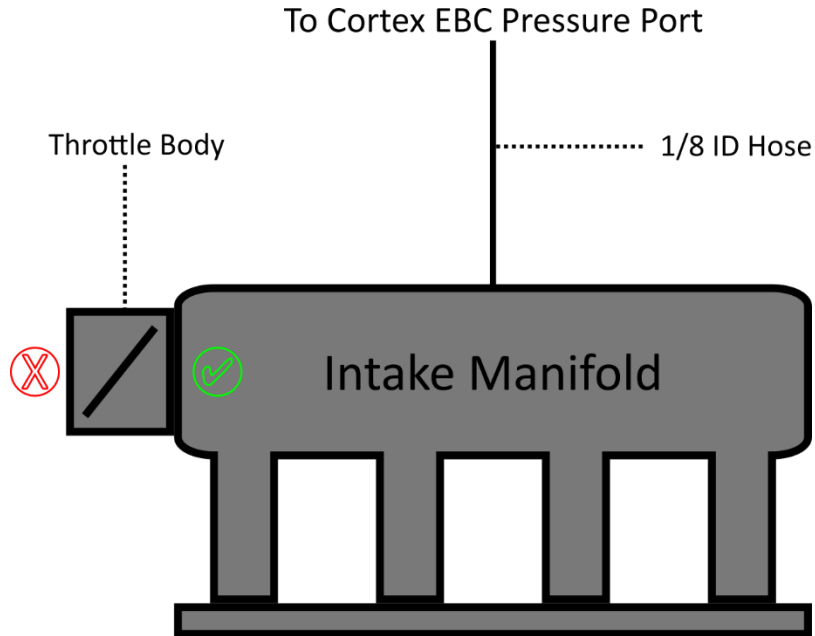

3-PORT INTERNAL WASTEGATE/ACTUATOR CONFIGURATION

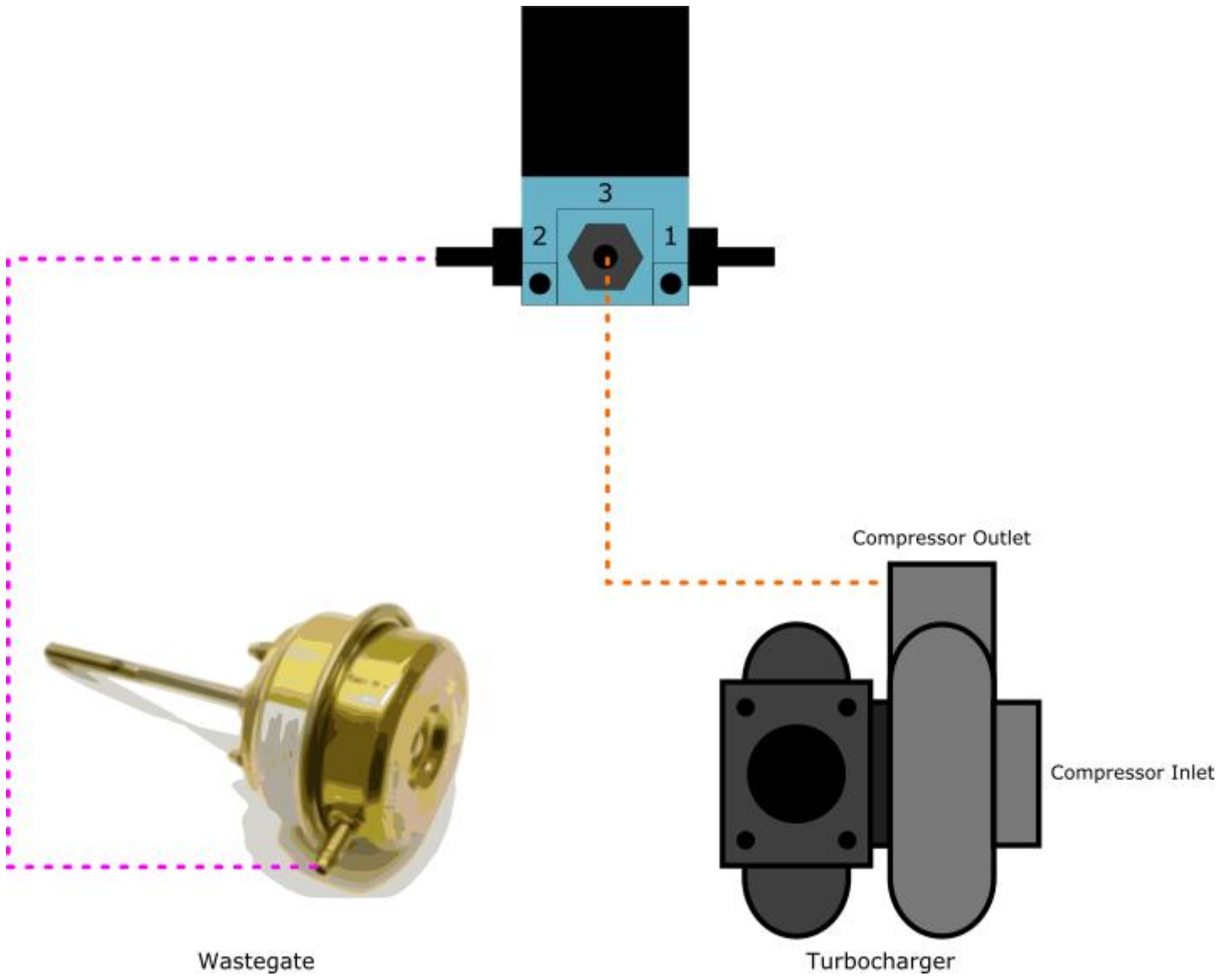

BCS Port 1	Leave open to the atmosphere.
BCS Port 2	Connect to the pressure port on the wastegate actuator.
BCS Port 3	Connect to a <b>dedicated</b> pressure reference that is as close to the compressor outlet on the turbo as possible. <b>DO NOT connect to a pressure reference on the intake manifold.</b>

### 3-PORT EXTERNAL WASTEGATE CONFIGURATION 1

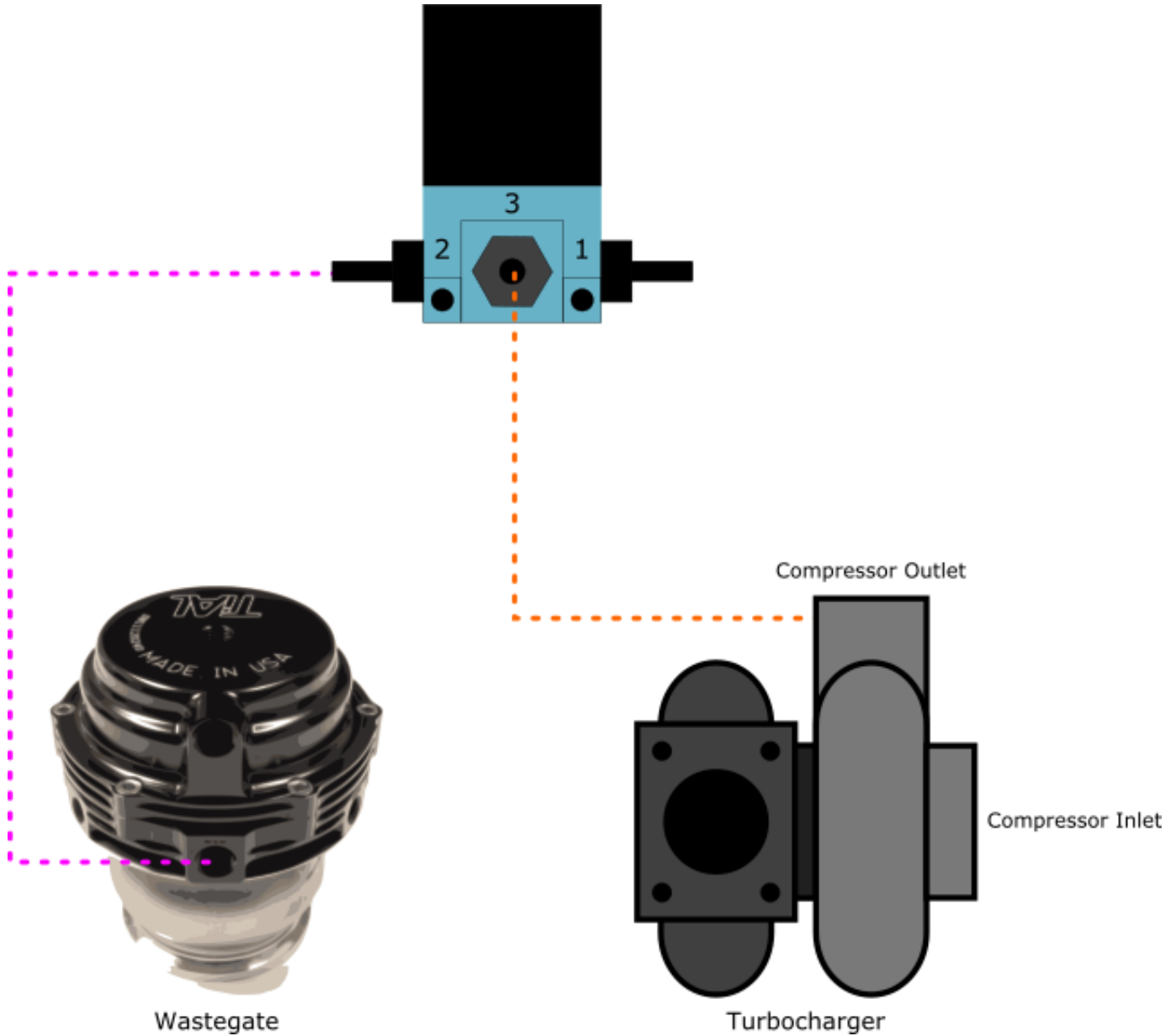

<b>BCS Port 1</b>	Leave open to the atmosphere.
<b>BCS Port 2</b>	Connect to a pressure port on the bottom wastegate chamber. Plug any additional pressure ports on the bottom wastegate chamber. <b>NOTE:</b> Leave pressure ports on the top wastegate chamber open to the atmosphere.
<b>BCS Port 3</b>	Connect to a <b>dedicated</b> pressure reference that is as close to the compressor outlet on the turbo as possible. <b>DO NOT connect to a pressure reference on the intake manifold.</b>

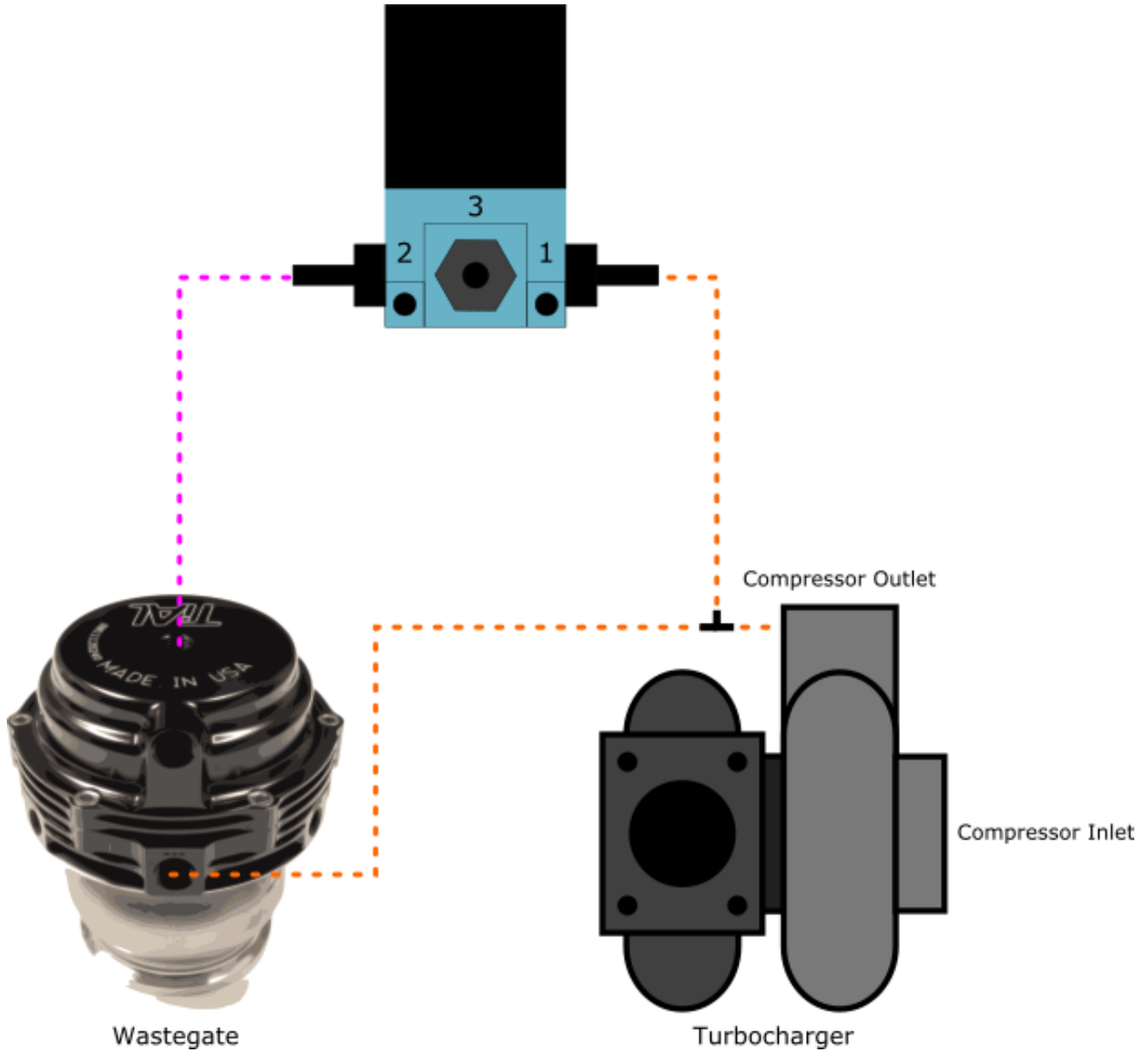

BCS Port 1	Using a hose tee fitting, connect to a <b>dedicated</b> pressure reference that is as close to the compressor outlet on the turbo as possible <b>AND</b> connect to a pressure port on the bottom wastegate chamber. Plug any remaining pressure ports on the bottom wastegate chamber. <b>DO NOT connect to a pressure reference on the intake manifold.</b>
BCS Port 2	Connect to a pressure port on the top wastegate chamber. Plug any remaining pressure ports on the top wastegate chamber.
BCS Port 3	Leave open to the atmosphere.

### 3-PORT EXTERNAL WASTEGATE COMPRESSED AIR CONFIGURATION

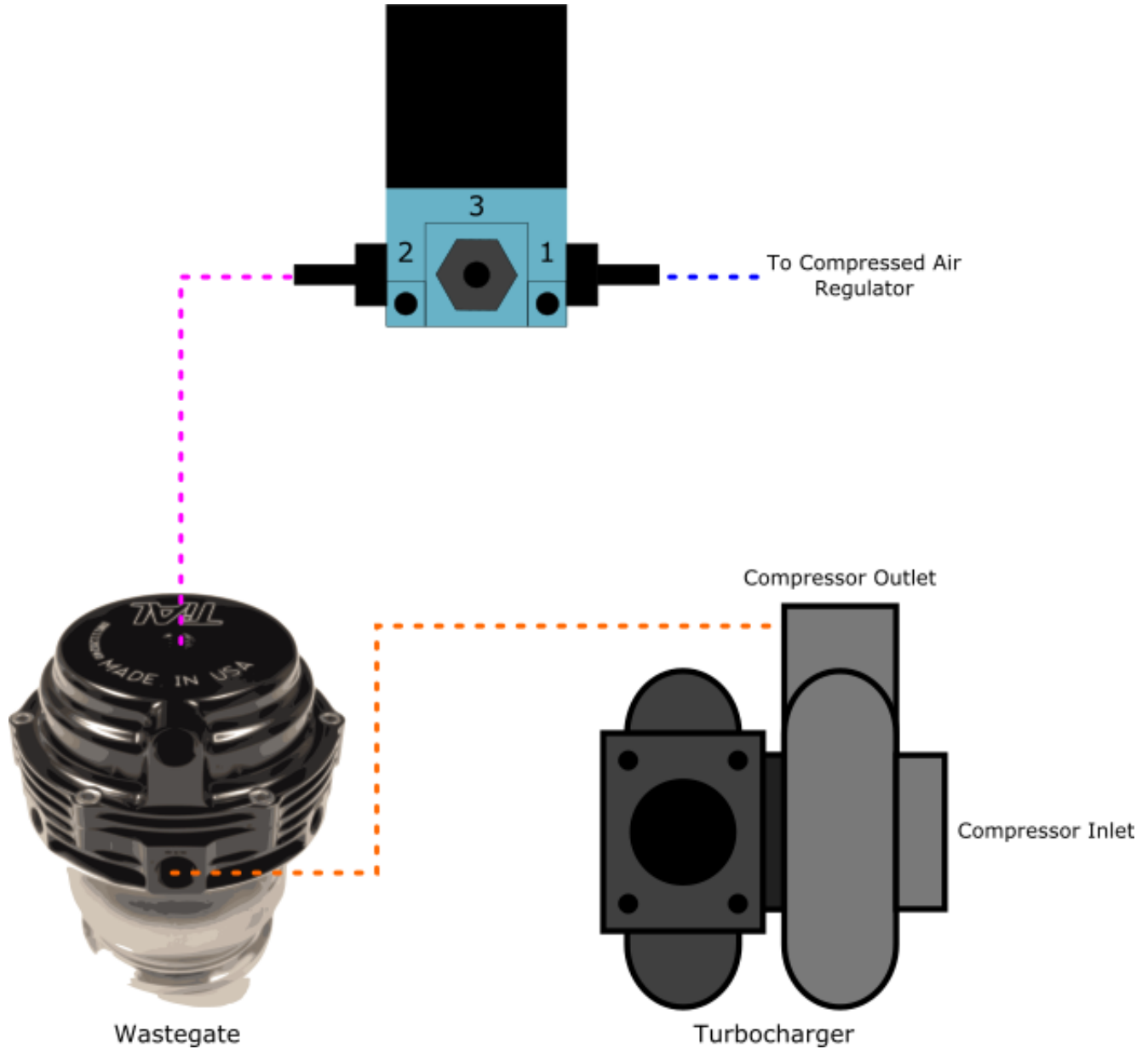

<b>BCS Port 1</b>	Connect to compressed air regulator.
<b>BCS Port 2</b>	Connect to a pressure port on the top wastegate chamber. Plug any remaining pressure ports on the top wastegate chamber.
<b>BCS Port 3</b>	Leave open to the atmosphere.
<b>Additional Connections</b>	Connect a pressure port on the bottom wastegate chamber to a <b>dedicated</b> pressure reference that is as close to the compressor outlet on the turbo as possible. Plug any remaining pressure ports on the bottom wastegate chamber. <b>DO NOT connect to a pressure reference on the intake manifold.</b>

4-PORT EXTERNAL WASTEGATE CONFIGURATION

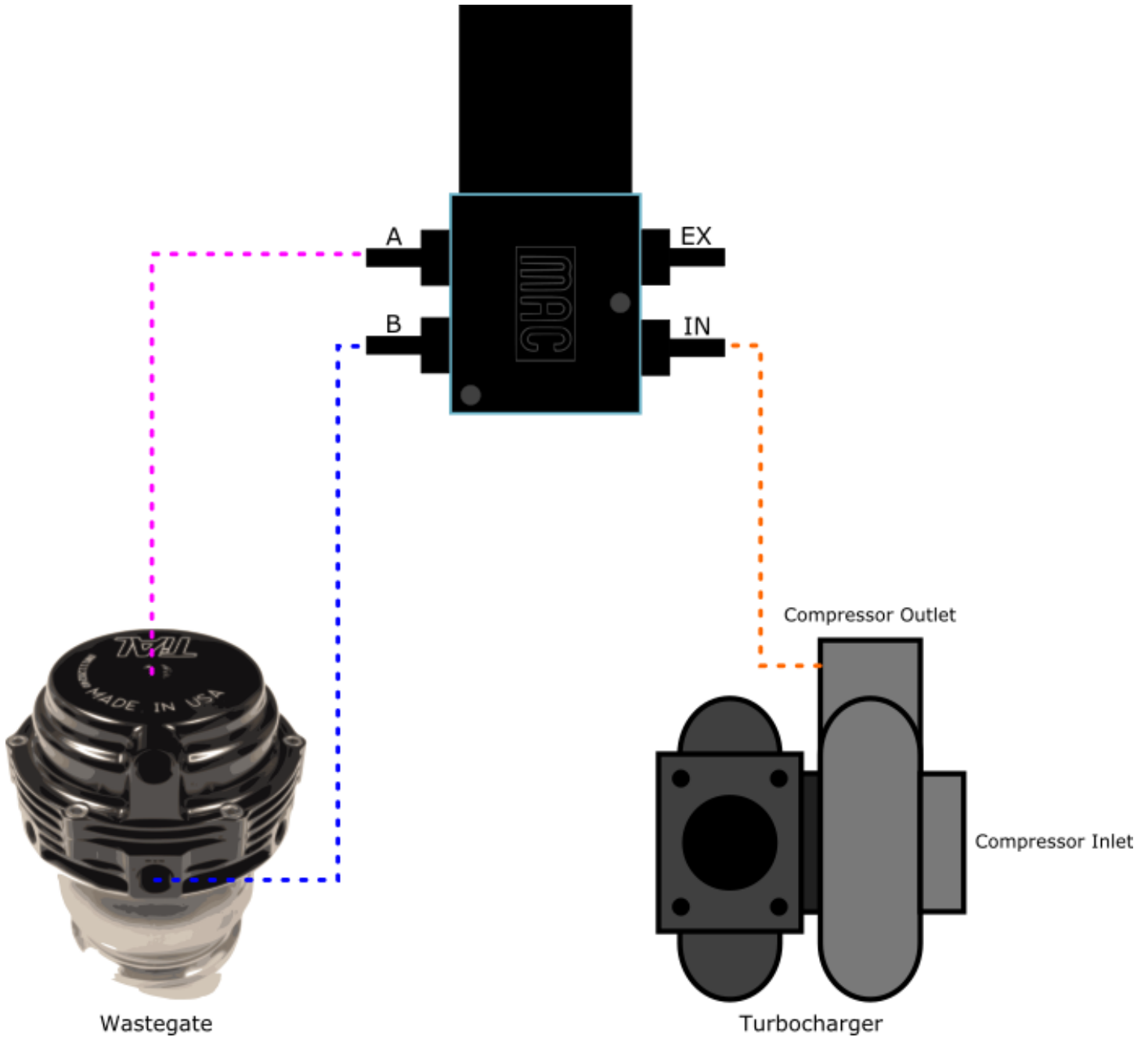

BCS Port IN	Connect to a <b>dedicated</b> pressure reference that is as close to the compressor outlet on the turbo as possible. <b>DO NOT connect to a pressure reference on the intake manifold.</b>
BCS Port B	Connect to a pressure port on the lower wastegate chamber. Plug any remaining pressure ports on the lower wastegate chamber.
BCS Port EX	Leave open to the atmosphere.
BCS Port A	Connect to a pressure port on the top wastegate chamber. Plug any remaining pressure ports on the top wastegate chamber.

3-PORT INTERNAL WASTEGATE/ACTUATOR CONFIGURATION

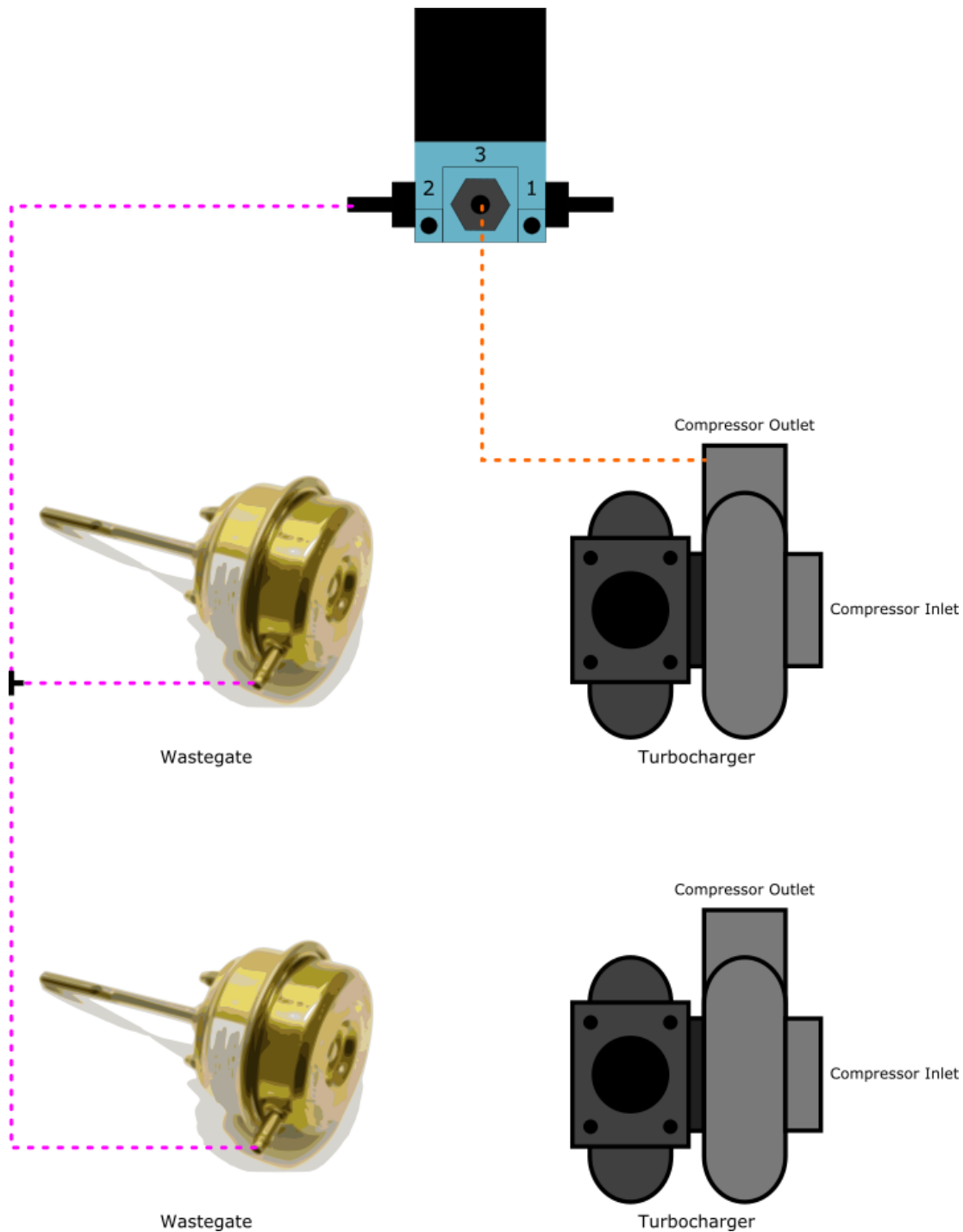

<b>BCS Port 1</b>	Leave open to the atmosphere.
<b>BCS Port 2</b>	Use a hose tee fitting to connect to the pressure ports on both wastegates.
<b>BCS Port 3</b>	Connect to a <b>dedicated</b> pressure reference that is as close to the compressor outlet of one of the turbos as possible. Plug the pressure port on the compressor outlet of the remaining turbo (if present). <b>DO NOT connect to a pressure reference on the intake manifold.</b>

### 3-PORT EXTERNAL WASTEGATE CONFIGURATION 1

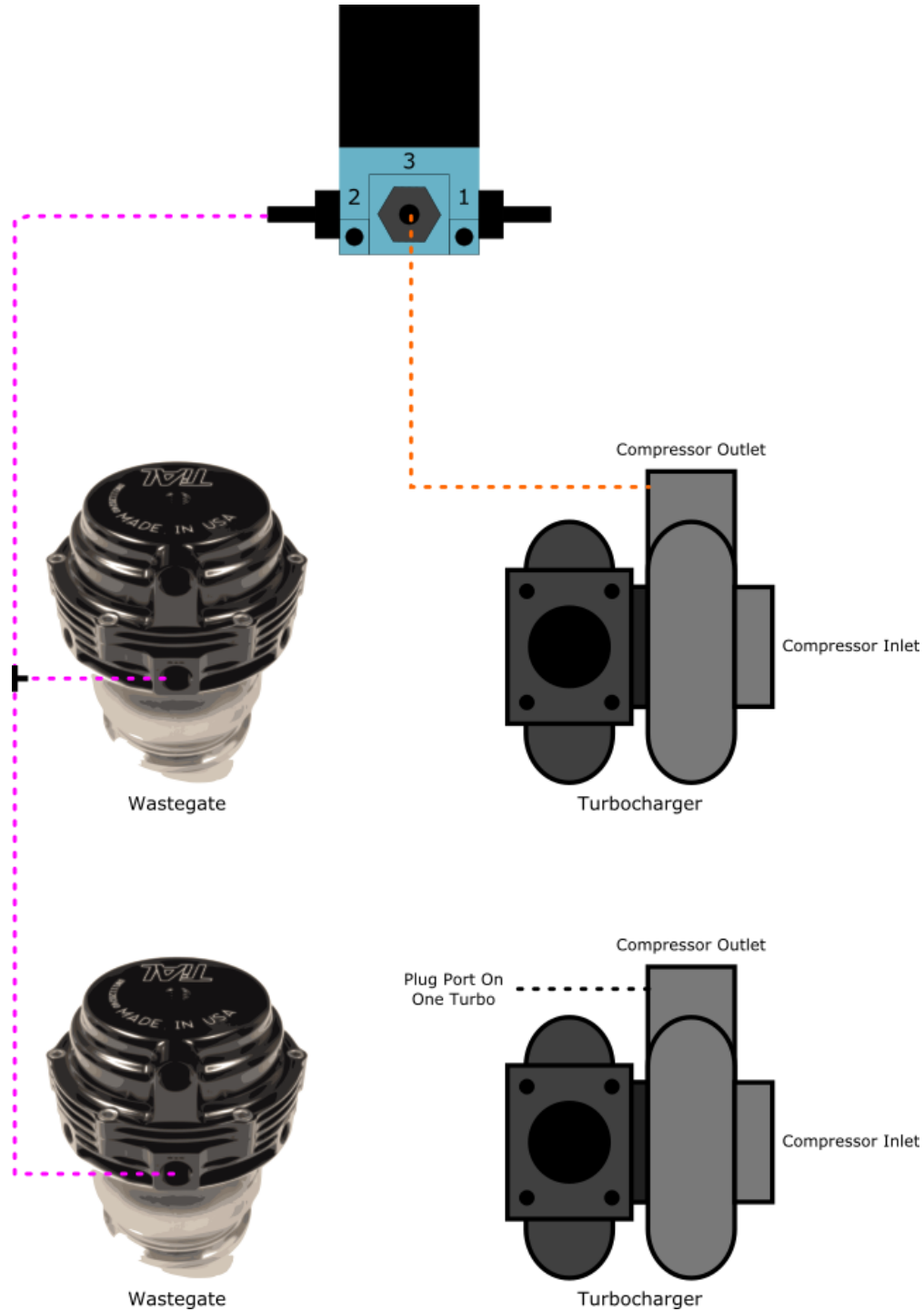

<b>BCS Port 1</b>	Leave open to the atmosphere.
<b>BCS Port 2</b>	Use a hose tee fitting to connect to a pressure port on both bottom wastegate chambers. Plug any additional pressure ports on the bottom wastegate chambers. <b>NOTE:</b> Leave pressure ports on the top wastegate chambers open to the atmosphere.
<b>BCS Port 3</b>	Connect to a <b>dedicated</b> pressure reference that is as close to the compressor outlet of one of the turbos as possible. Plug the pressure port on the compressor outlet of the remaining turbo (if present). <b>DO NOT connect to a pressure reference on the intake manifold.</b>

### 3-PORT EXTERNAL WASTEGATE CONFIGURATION 2

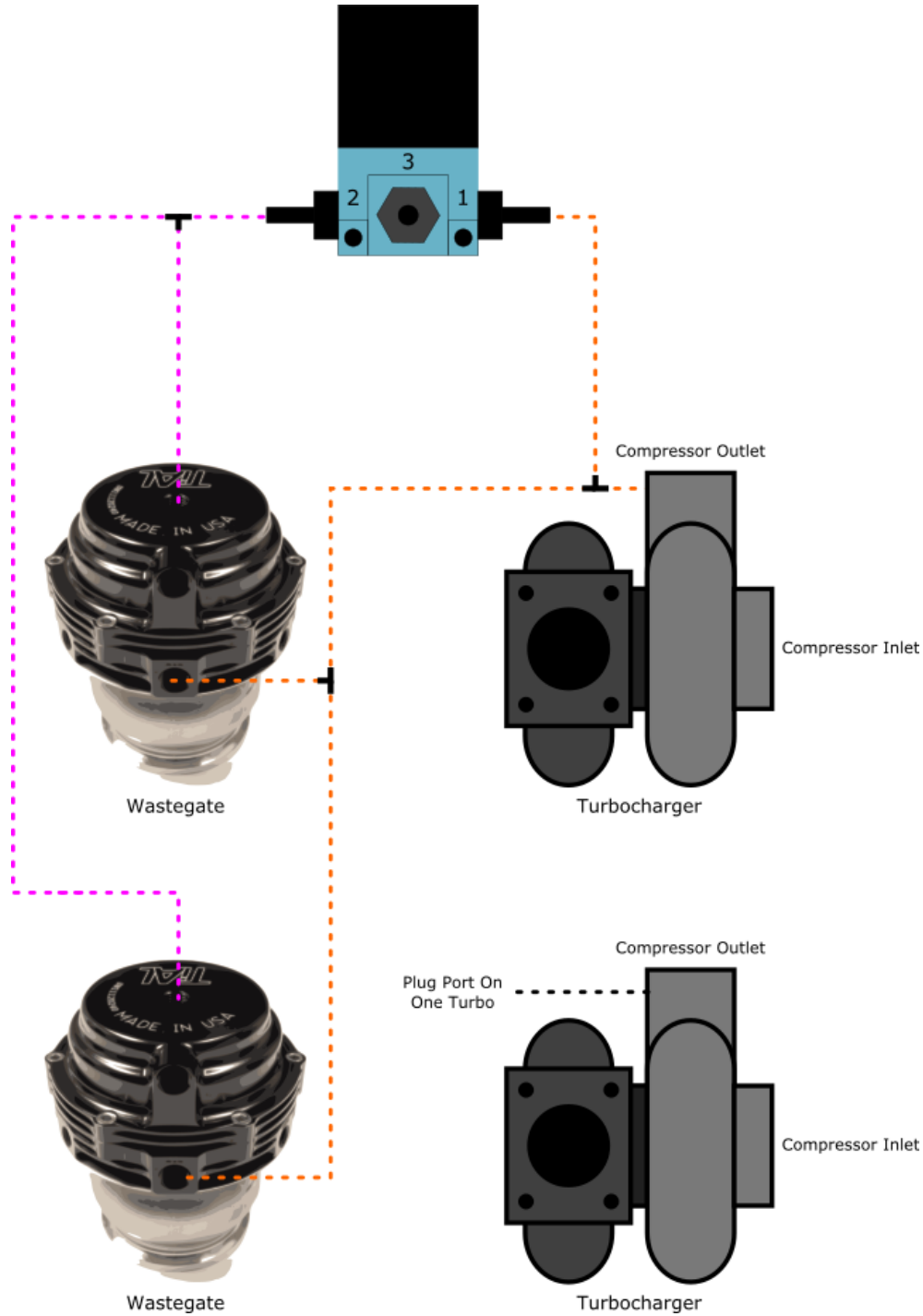

<p><b>BCS Port 1</b></p>	<p>Use two hose tee fittings to connect to a <b>dedicated</b> pressure reference that is as close to the compressor outlet of one of the turbos as possible <b>AND</b> connect to a pressure port on both bottom wastegate chambers. Plug the pressure port on the compressor outlet of the remaining turbo (if present). Plug any remaining pressure ports on the bottom wastegate chambers.</p> <p><b>DO NOT connect to a pressure reference on the intake manifold.</b></p>
<p><b>BCS Port 2</b></p>	<p>Use a hose tee fitting to connect to a pressure port on both top wastegate chambers. Plug any remaining pressure ports on the top wastegate chambers.</p>
<p><b>BCS Port 3</b></p>	<p>Leave open to the atmosphere.</p>

### 3-PORT EXTERNAL WASTEGATE COMPRESSED AIR CONFIGURATION

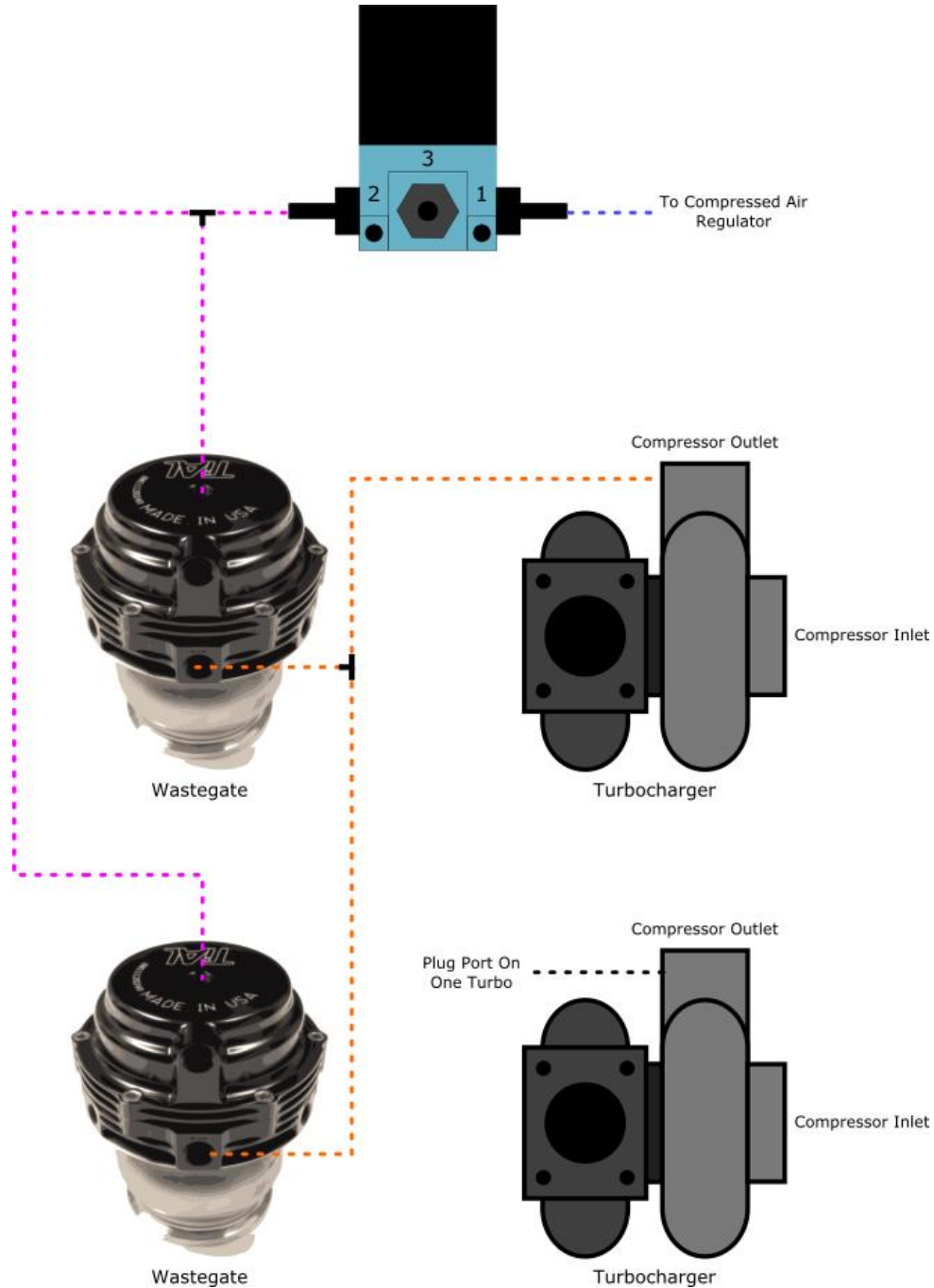

<b>BCS Port 1</b>	Connect to compressed air regulator.
<b>BCS Port 2</b>	Use a hose tee fitting to connect to a pressure port on both top wastegate chambers. Plug any remaining pressure ports on the top wastegate chambers.
<b>BCS Port 3</b>	Leave open to the atmosphere.
<b>Additional Connections</b>	Use a hose tee fitting to connect a pressure port on both bottom wastegate chambers to a <b>dedicated</b> pressure reference that is as close to the compressor outlet on one of the turbos as possible. Plug the pressure port on the compressor outlet of the remaining turbo (if present). Plug any remaining pressure ports on the bottom wastegate chambers. <b>DO NOT connect to a pressure reference on the intake manifold.</b>

## 4-PORT EXTERNAL WASTEGATE CONFIGURATION

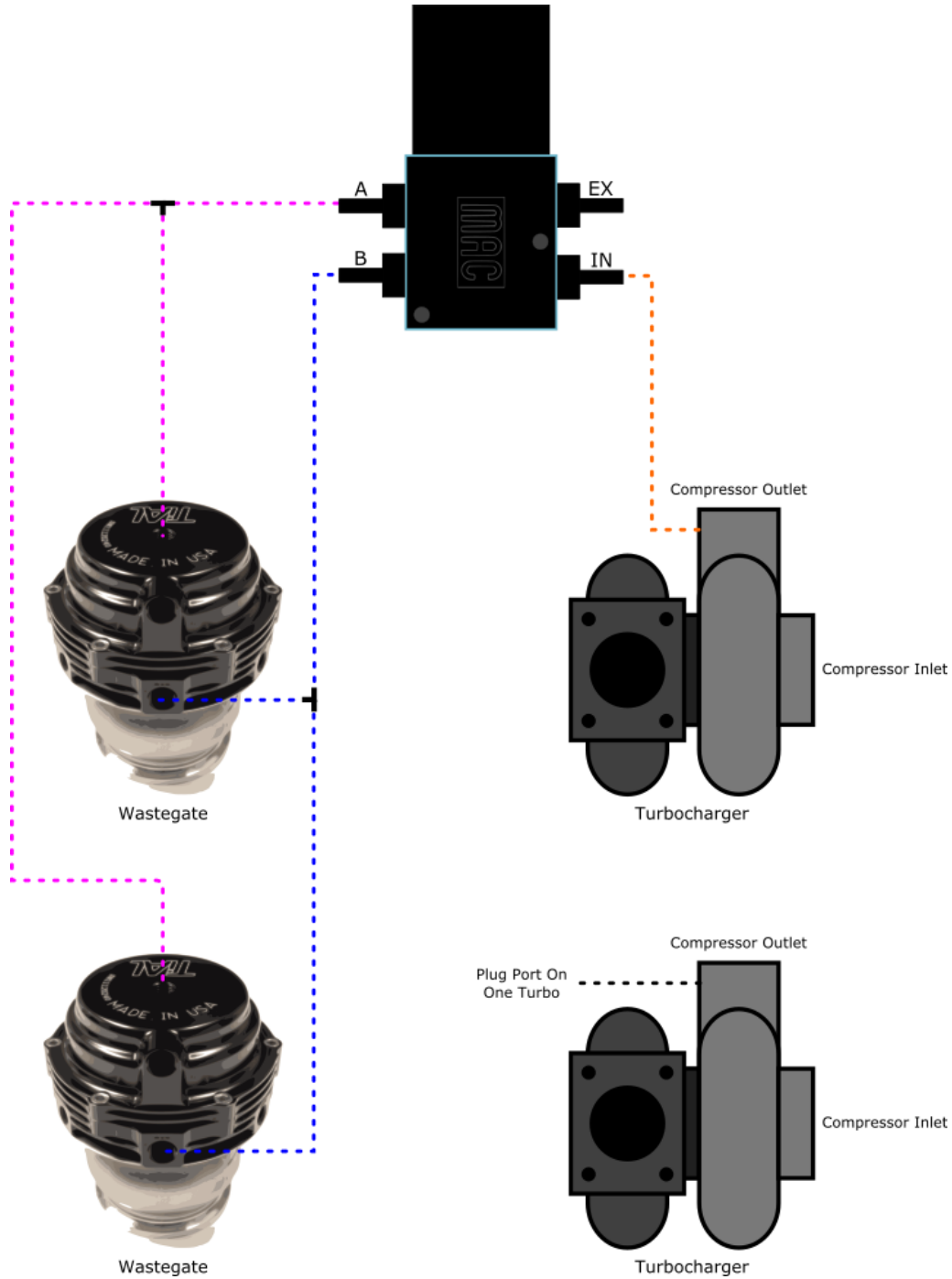

<b>BCS Port IN</b>	Use a hose tee fitting to connect to a <b>dedicated</b> pressure reference that is as close to the compressor outlet on one of the turbos as possible. Plug the pressure port on the compressor outlet of the remaining turbo (if present). <b>DO NOT connect to a pressure reference on the intake manifold.</b>
<b>BCS Port B</b>	Connect to a pressure port on both bottom wastegate chambers using a hose tee fitting. Plug any remaining pressure ports on the bottom wastegate chamber.
<b>BCS Port EX</b>	Leave open to the atmosphere.
<b>BCS Port A</b>	Use a hose tee fitting to connect to a pressure port on both top wastegate chambers. Plug any remaining pressure ports on the top wastegate chambers.

The two buttons and the 7-segment LED display on the front of the Cortex EBC are used to manage the controller's basic operations. Typically, the LED display functions as a configurable gauge that can show various parameters, such as boost pressure and solenoid duty cycle. Pressing the top button activates a user-selectable function, while pressing the bottom button opens the controller's menu system.

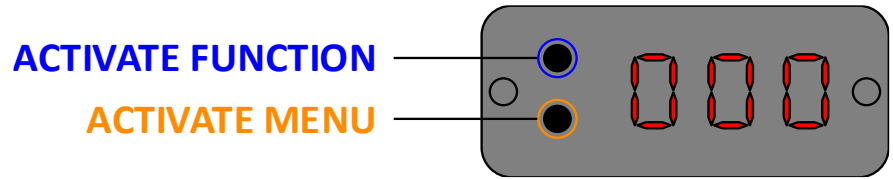

While the Cortex EBC is primarily configured using the Cortex Config software, the following actions can only be carried out using the buttons on the front of the controller:

- Changing the active boost control profile.
- Enabling the internal logging function.
- Enabling the auxiliary outputs (the activation is determined by software settings).
- Changing the top button function mode.
- Changing the gauge data shown on the LED display (boost, solenoid duty cycle, engine speed, etc.).
- Changing the units used for boost data shown on the LED display (PSI or Bar).
- Changing the brightness of the LED display.

In general, the actions listed above are carried out through the following five steps:

1. Press the **bottom** button on the front of the Cortex EBC to activate the menu system.
2. Use the **scroll** button (top) to scroll through the menu options.
3. Press the **select** button (bottom) to enter the submenu for the currently selected option.
4. Use the **scroll** button to scroll through the submenu options.
5. Press the **select** button to finalize the selection and exit the menu system.

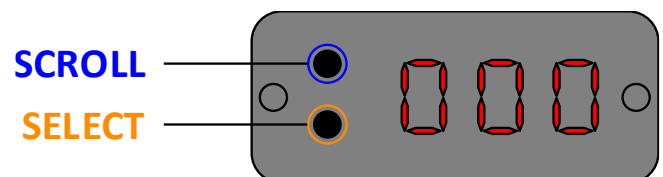

## TOP BUTTON FUNCTION MODE

The top button on the front of the Cortex EBC can be configured to activate one of four available functions.

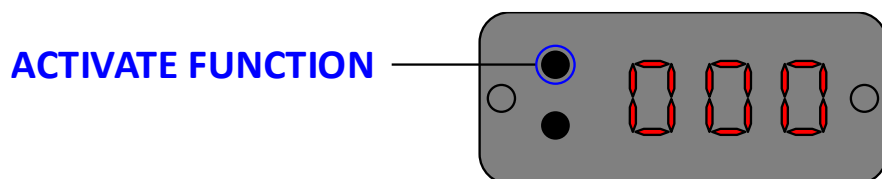

**Peak boost recall mode** – Pressing the top button will recall the highest boost pressure reached since the controller was powered on. This value can be reset by pressing/holding the top button for 2 seconds.

**Transbrake bump control mode** – Pressing the top button will activate the transbrake bump function. Each time the top button is pressed the transbrake will be interrupted for the time specified in the output configuration file programmed to the controller.

**Boost scramble control mode** – Pressing the top button once will activate the boost scramble control function. The boost scramble control will remain activated until the top button is pressed for a second time.

**Auxiliary output test mode** – Pressing/holding the top button for 2 seconds will activate any enabled auxiliary outputs at 100% duty cycle (fully on). The output(s) will remain activated until the top button is pressed again or until 30 seconds have passed.

See [this section](#) to learn how to change the top button function mode.

## MENU SYSTEM

The menu system can be activated at any time by pressing the **bottom** button on the front of the Cortex EBC.

**ACTIVATE MENU**

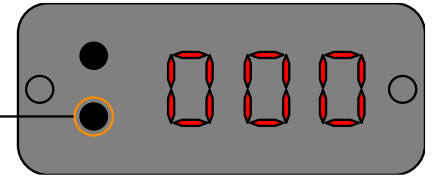

After activating the menu system, pressing the **top** button will allow you to navigate through the various submenu options. Pressing the **bottom** button will enter the submenu corresponding to the text that is being scrolled across the LED display.

**SCROLL THROUGH SUBMENU OPTIONS**

**ENTER SELECTED SUBMENU**

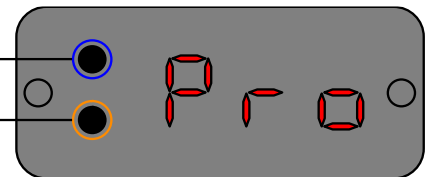

MAIN MENU OPTION	ACTION
<b>ProFILE</b> (profile)	Enter the boost control profile submenu.
<b>IntErnAL Logging</b> (internal logging)	Enter the internal logger submenu.
<b>outPut 1</b> (output 1)	Enter the output 1 submenu.
<b>outPut 2</b> (output 2)	Enter the output 2 submenu.
<b>toP button Function</b> (top button function)	Enter the top button function submenu.
<b>gAugE dAtA</b> (gauge data)	Enter the gauge data submenu.
<b>boost units</b> (boost units)	Enter the boost units submenu.
<b>disPLAy brIghtnESS</b> (display brightness)	Enter the display brightness submenu.
<b>done</b> (done)	Exit the menu system.

## CHANGING BOOST CONTROL PROFILE

To change the active boost control profile, begin by pressing the **bottom** button on the front of the Cortex EBC to activate the menu system.

**ACTIVATE MENU**

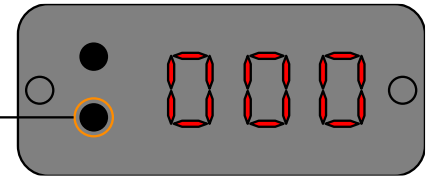

When the menu system is activated, **P r o F I L E** (profile) will scroll across the LED display. Press the **top** button to enter the boost control profile submenu.

**ENTER BOOST CONTROL PROFILE SUBMENU**

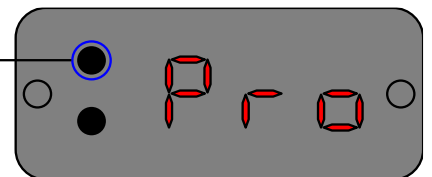

Repeatedly press the **top** button to navigate through the available profiles (profile 3 shown below).

**SCROLL THROUGH PROFILE OPTIONS**

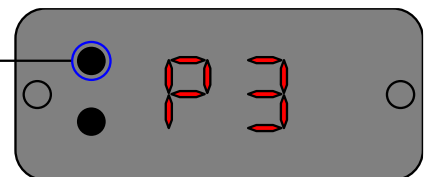

To disable boost control, navigate to the **O F F** (off) profile.

**SCROLL THROUGH PROFILE OPTIONS**

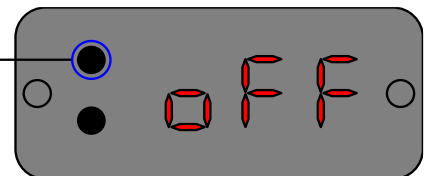

Press the **bottom** button to activate the selected profile and exit the menu system.

**SELECT PROFILE AND EXIT MENU SYSTEM**

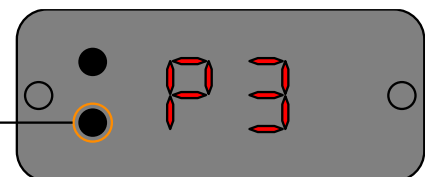

## ENABLING INTERNAL LOGGER

To enable or disable the internal logging function, begin by pressing the **bottom** button on the front of the Cortex EBC to activate the menu system.

**ACTIVATE MENU**

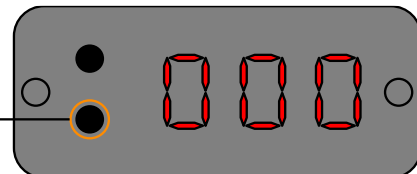

Repeatedly press the **top** button until **intErnAL Logging** (internal logging) scrolls across the LED display.

**SCROLL THROUGH MAIN MENU OPTIONS**

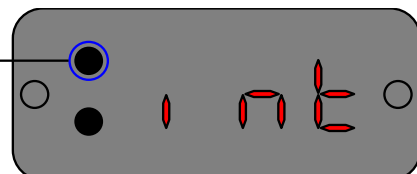

Press the **bottom** button to enter the internal logging submenu.

**ENTER INTERNAL LOGGING SUBMENU**

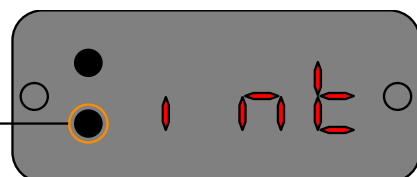

Repeatedly press the **top** button to navigate through the boost thresholds (in PSI) over which the internal logger will start recording data. Logging can be activated at 0.5, 1.0, 1.5, 2.0, or 2.5 PSI (2.5 PSI shown below). To disable the internal logger, navigate to **OFF** (off).

**SCROLL THROUGH LOGGER ACTIVATION OPTIONS**

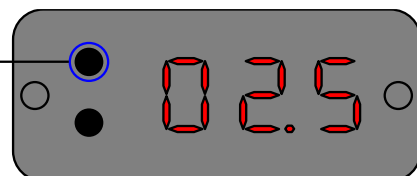

Press the **bottom** button to save the internal logger settings and exit the menu system.

**SAVE SELECTION AND EXIT MENU SYSTEM**

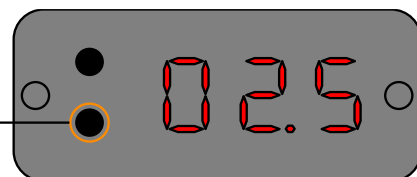

See [this section](#) to learn more about the internal logging function.

## ENABLING AUXILIARY OUTPUTS

To enable or disable the auxiliary outputs, begin by pressing the **bottom** button on the front of the Cortex EBC to activate the menu system.

**ACTIVATE MENU**

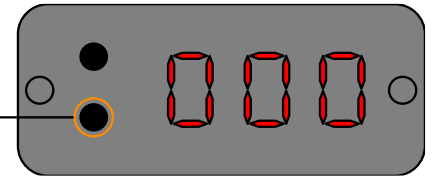

Repeatedly press the **top** button until **outPut 1** (output 1) or **outPut 2** (output 2) scrolls across the LED display.

**SCROLL THROUGH MAIN MENU OPTIONS**

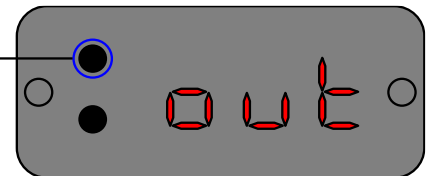

Press the **bottom** button to enter the output 1 or output 2 submenu.

**ENTER OUTPUT 1 OR 2 SUBMENU**

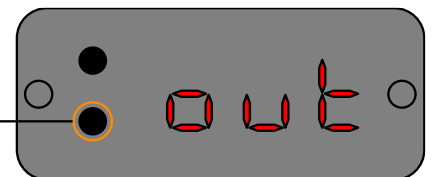

Repeatedly press the **top** button to navigate through the operating modes for the corresponding output. Navigate to **OFF** (off) to disable the corresponding output. Navigate to **EnAbLEd** (enabled) to enable the corresponding output.

**SCROLL THROUGH OUTPUT OPERATING MODES**

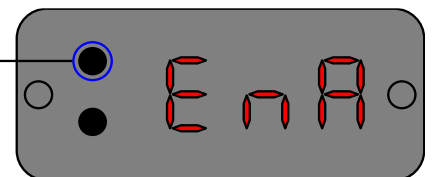

Press the **bottom** button to save the operating mode for the corresponding output and exit the menu system.

**SAVE SELECTION AND EXIT MENU SYSTEM**

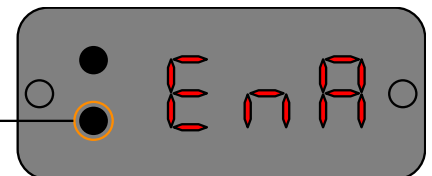

See [this section](#) for information on auxiliary output wiring.

See [this section](#) for information on auxiliary output configuration.

## CHANGING TOP BUTTON FUNCTION MODE

To change the top button function mode, begin by pressing the **bottom** button on the front of the Cortex EBC to activate the menu system.

**ACTIVATE MENU**

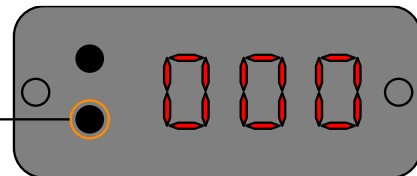

Repeatedly press the **top** button until **t o P b u t t o n F u n c t i o n** (top button function) scrolls across the LED display.

**SCROLL THROUGH MAIN MENU OPTIONS**

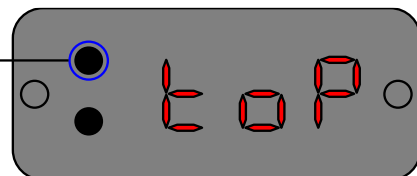

Press the **bottom** button to enter the top button function mode menu.

**ENTER TOP BUTTON FUNCTION MODE SUBMENU**

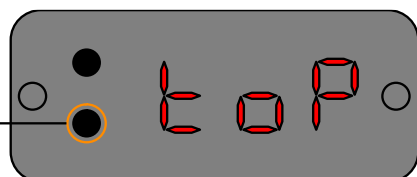

Repeatedly press the **top** button to navigate through the operating modes for the top button function. See the table on the following page for a complete list of the available operating modes.

**SCROLL THROUGH TOP BUTTON FUNCTION MODES**

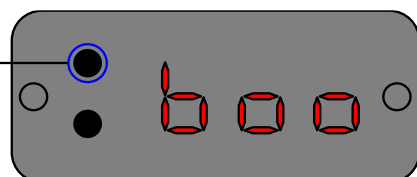

Press the **bottom** button to save the operating mode for the top button function and exit the menu system.

**SAVE SELECTION AND EXIT MENU SYSTEM**

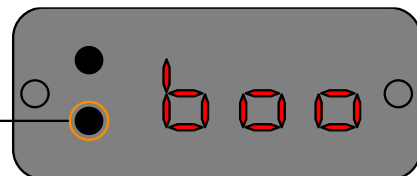

SUBMENU OPTION	TOP BUTTON FUNCTION
<b>b o o S t r e c A L L</b> (boost recall)	Peak boost recall mode
<b>t r A n S t A g E</b> (trans stage)	Transbrake bump control mode
<b>b o o S t S c r A b L E</b> (boost scrable)	Boost scramble control mode
<b>t E S t o u t P u t s</b> (test outputs)	Auxiliary output test mode

See [this section](#) to learn more about the top button function modes.

## CHANGING GAUGE DATA

To change the type of data that is shown on the gauge, begin by pressing the **bottom** button on the front of the Cortex EBC to activate the menu system.

**ACTIVATE MENU**

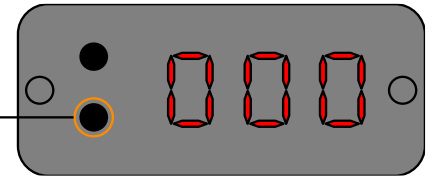

Repeatedly press the **top** button until **gA u g E d A t A** (gauge data) scrolls across the LED display.

**SCROLL THROUGH MAIN MENU OPTIONS**

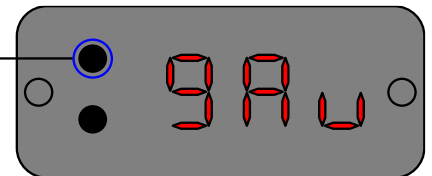

Press the **bottom** button to enter the gauge data submenu.

**ENTER GAUGE DATA SUBMENU**

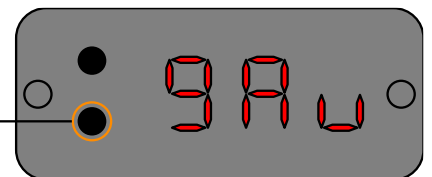

Repeatedly press the **top** button to navigate through the data types that can be shown by the gauge. See the table on the following page for the complete list of the available data types.

**SCROLL THROUGH DATA TYPES**

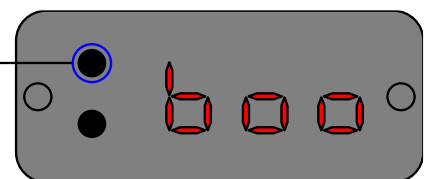

Press the bottom **bottom** button to save the data type to be shown by the gauge and exit the menu system.

**SAVE SELECTION AND EXIT MENU SYSTEM**

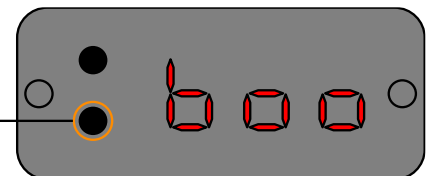

SUBMENU OPTION	LED DISPLAY WILL SHOW
<b>booS</b> t (boost)	Boost pressure (positive pressure only)
<b>duTy cYcLE</b> (duty cycle)	Boost control solenoid duty cycle
<b>EnginE SpEEd</b> (engine speed)	Calculated engine speed in RPM
<b>SpEEd</b> (speed)	Calculated vehicle speed in MPH
<b>gPi</b> (GPI)	Scaled data from the analog or digital sensor connected to the general-purpose input
<b>gEAR</b> (gear)	Gear (11 shown if boost scramble control function is activated)
<b>EVS rAtio</b> (EVS Ratio)	EVS ratio for gear detection
<b>SpEEd unScALEd</b> (speed unscaled)	Raw speed signal frequency in Hz
<b>gPi unScALEd</b> (GPI unscaled)	Raw voltage or frequency from the analog or digital sensor connected to the general-purpose input.

## CHANGING BOOST UNITS

To change the units used for boost data shown on the LED display, begin by pressing the **bottom** button on the front of the Cortex EBC to activate the menu system.

**ACTIVATE MENU**

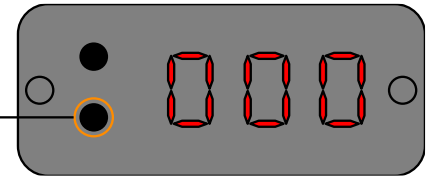

Repeatedly press the **top** button until **b o o S t u n i t S** (boost units) scrolls across the LED display.

**SCROLL THROUGH MAIN MENU OPTIONS**

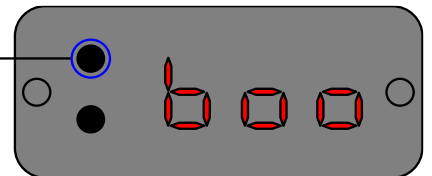

Press the **bottom** button to enter the boost units submenu.

**ENTER BOOST UNITS SUBMENU**

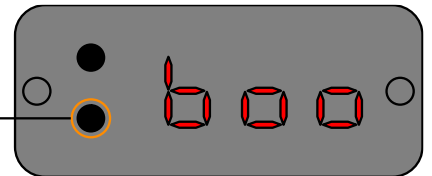

Repeatedly press the **top** button to navigate through the boost units options. To display boost in PSI units, navigate to **P S i** (PSI). To display boost in Bar units, navigate to **B A r** (Bar).

**SCROLL THROUGH BOOST UNITS OPTIONS**

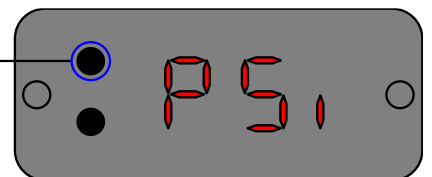

Press the **bottom** button to save the boost units selection and exit the menu system.

**SAVE SELECTION AND EXIT MENU SYSTEM**

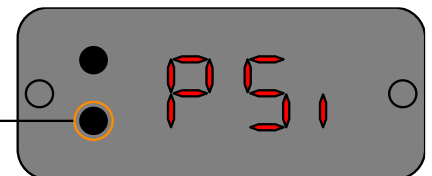

## CHANGING DISPLAY BRIGHTNESS

To change the brightness of the LED display, begin by pressing the **bottom** button on the front of the Cortex EBC to activate the menu system.

**ACTIVATE MENU**

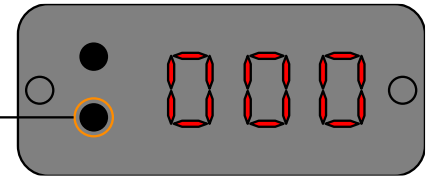

Repeatedly press the **top** button until **d i S P L A y b r i g h t n E S S** (display brightness) scrolls across the LED display.

**SCROLL THROUGH MAIN MENU OPTIONS**

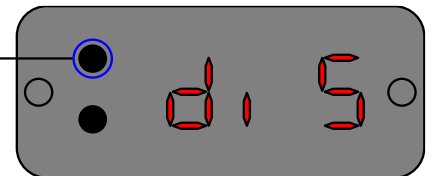

Press the **bottom** button to enter the display brightness submenu.

**ENTER THE DISPLAY BRIGHTNESS SUBMENU**

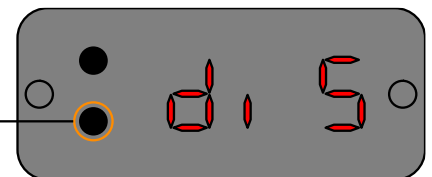

Repeatedly press the **top** button to navigate through the display brightness levels (1-5 with 5 being the brightest).

**SCROLL THROUGH DISPLAY BRIGHTNESS LEVELS**

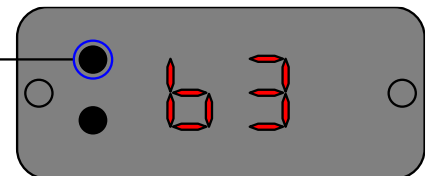

Press the **bottom** button to save the brightness selection and exit the menu system.

**SAVE SELECTION AND EXIT MENU SYSTEM**

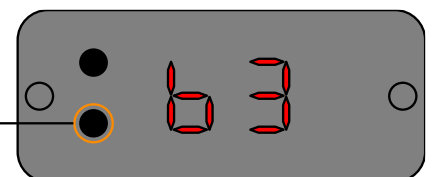

The main window for the Cortex Config software is shown below. Most actions can be performed using the toolbar at the top of the main software window.

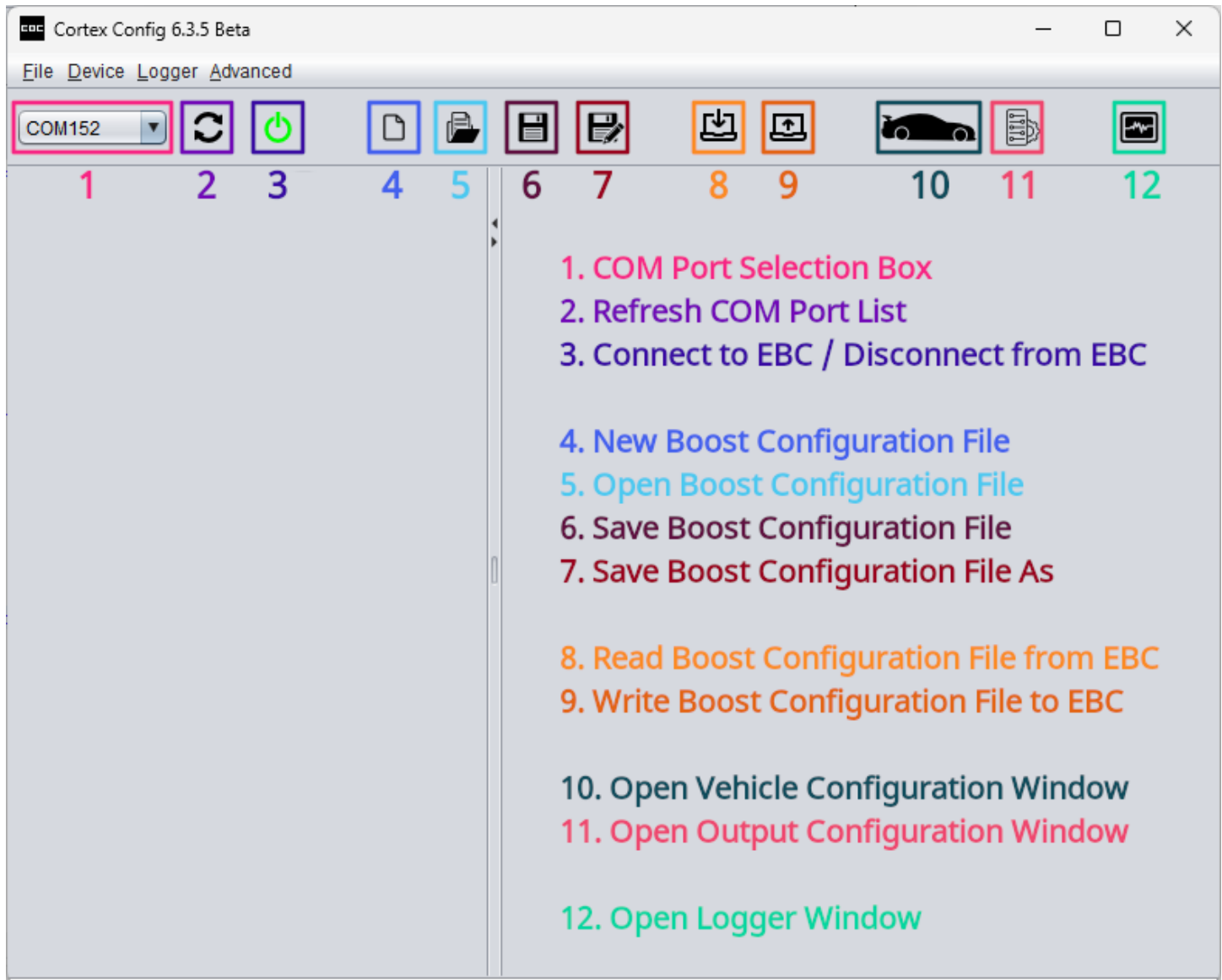

## USB CONNECTION

Before establishing a USB connection with the Cortex EBC, the device must be powered by 12 Volts through the wiring harness. Your computer will detect the Cortex EBC if the device is not powered through the wiring harness, but you will not be able to communicate with it.

Click the button next to the COM Port selection box if the software has been opened before the USB cable is connected to the computer.

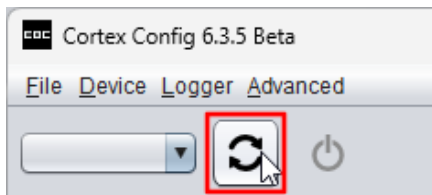

Select the COM Port that has been assigned to your Cortex EBC device from the list of available ports. There may be more than one port listed in the dropdown box if you have multiple devices connected to your computer. If you are unsure which port has been assigned to your Cortex EBC, unplug the USB cables for the other devices and then refresh the COM Port list.

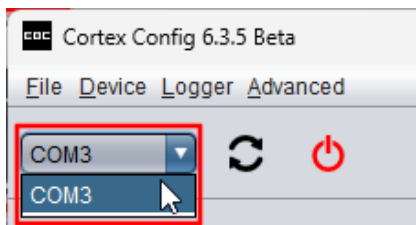

Click the Connect button to establish a USB connection with the Cortex EBC.

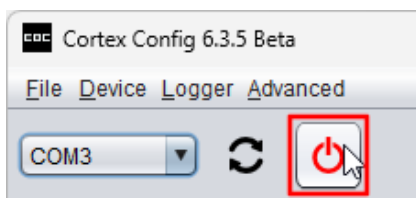

## VIEWING AND EDITING BOOST CONFIGURATION FILES

After loading a boost configuration file into the Cortex Config software, the control settings can be accessed using the navigation tree on the left side of the window (blue shaded area in the image below). Start Duty Cycle and Target Boost tables will be displayed on the right side of the main window (red shaded area in the image below). All other boost control settings are viewed and edited through pop-up dialog boxes.

**NOTE:** Changes are not automatically transferred to the controller's memory. For any new changes to take effect, you must first write the new settings to the Cortex EBC device.

The screenshot shows the Cortex Config 6.3.5 Beta software interface. The left sidebar (blue shaded area) displays a navigation tree with the following structure:

- Boost Configuration File
  - Profile 1 - Basic Strategy
    - Configuration
    - Open-Loop
      - Start Duty Cycle**
      - Spool Boost Control
      - Gear Change Overboost Control
    - Closed-Loop
    - Launch
    - Fail-Safes
  - Profile 2 - Basic Strategy
  - Profile 3 - Basic Strategy
  - Profile 4 - Basic Strategy
  - Profile 5 - Basic Strategy
  - Profile 6 - Basic Strategy

The main window (red shaded area) displays the configuration for 'PROFILE: 1 | START DUTY CYCLE [%]'. At the top, there are control buttons (+, -, X, =) and a value field set to '10.00', along with 'Copy', 'Paste', and 'Interpolate' options. Below this is a table with the following data:

	Start Duty Cycle (%)
Scramble	0.0
Gear 10	0.0
Gear 9	0.0
Gear 8	0.0
Gear 7	0.0
Gear 6	0.0
Gear 5	0.0
Gear 4	0.0
Gear 3	0.0
Gear 2	0.0
Gear 1	0.0

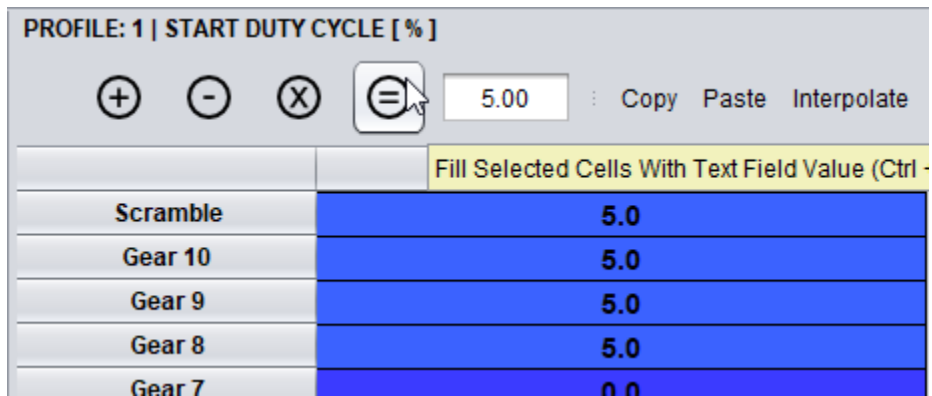

Table cells can either be set to a specified value or mathematically manipulated by a specified value (add, subtract, multiply).

To edit a table, first select the cells to be modified with the mouse. Once one or more cells have been selected, the cell modifier value can be set by typing the desired value. As you type, the modifier value will appear in the text field of the table’s toolbar.

After entering the modifier value, the cells can be updated by using the buttons in the table

toolbar or with keyboard shortcuts. The table shown below outlines the possible cell operations and their associated keyboard shortcuts.

OPERATION	DESCRIPTION	KEYBOARD SHORTCUT
<b>Add</b>	Add the modifier value to selected table cells	CTRL + I
<b>Subtract</b>	Subtract the modifier value from the selected table cells.	CTRL + D
<b>Multiply</b>	Multiply the selected cells by the modifier value.	CTRL + M
<b>Fill</b>	Set the selected cells to the modifier value.	CTRL + F or ENTER
<b>Copy</b>	Copy the selected cells to the system clipboard (spreadsheet compatible).	CTRL + C
<b>Paste</b>	Paste the contents of the system clipboard to the selected cell range.	CTRL + V
<b>Interpolate</b>	Interpolate the selected cell range.	CTRL + P
<b>Add 0.1</b>	Add 0.1 to all selected cells.	+
<b>Subtract 0.1</b>	Subtract 0.1 from all selected cells.	-

## PROFILE COPY/PASTE

The profile copy feature allows all boost control settings to be copied from a source profile to a destination profile. To use the profile copy feature, simply right-click on any setting from the source profile in the navigation pane.

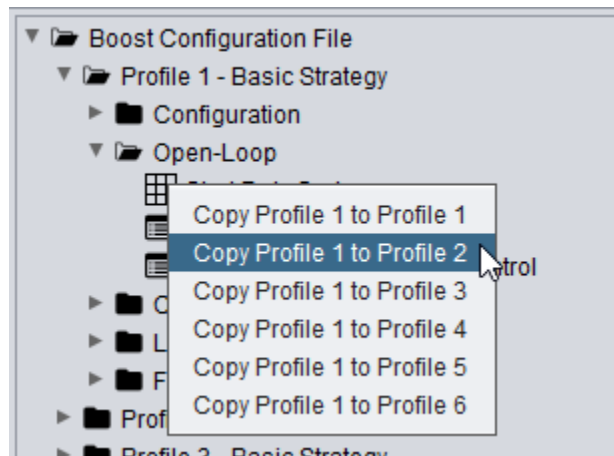

## GEAR-BASED DIALOG COPY/PASTE

When editing settings in gear-based dialogue boxes, the settings for the gear that is currently selected can be copied to a destination gear. To use this feature, simply right-click anywhere in the dialogue box.

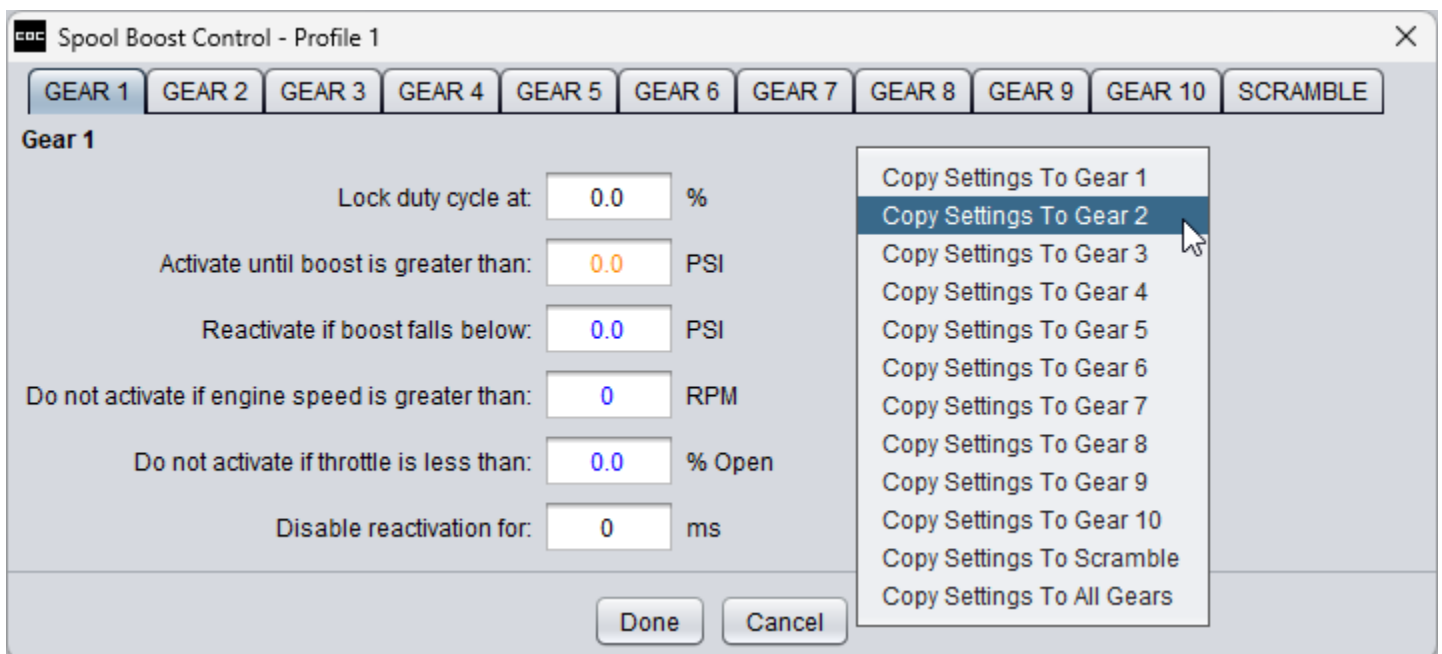

## DATA LOGGING

The Cortex Config software includes a built-in data logger that can be used to collect and display real-time data from the Cortex EBC. This data assists in making informed adjustments to control and output settings. When data is collected, the Boost Configuration, Vehicle Configuration, and Output Configuration settings from the Cortex EBC are stored with the data set. If the data set is saved to a computer, these device settings are also stored in the log file and can be loaded into the software for later review or analysis.

The logger window for the Cortex Config software is shown below. Most actions can be performed using the toolbar at the top of the logger window.

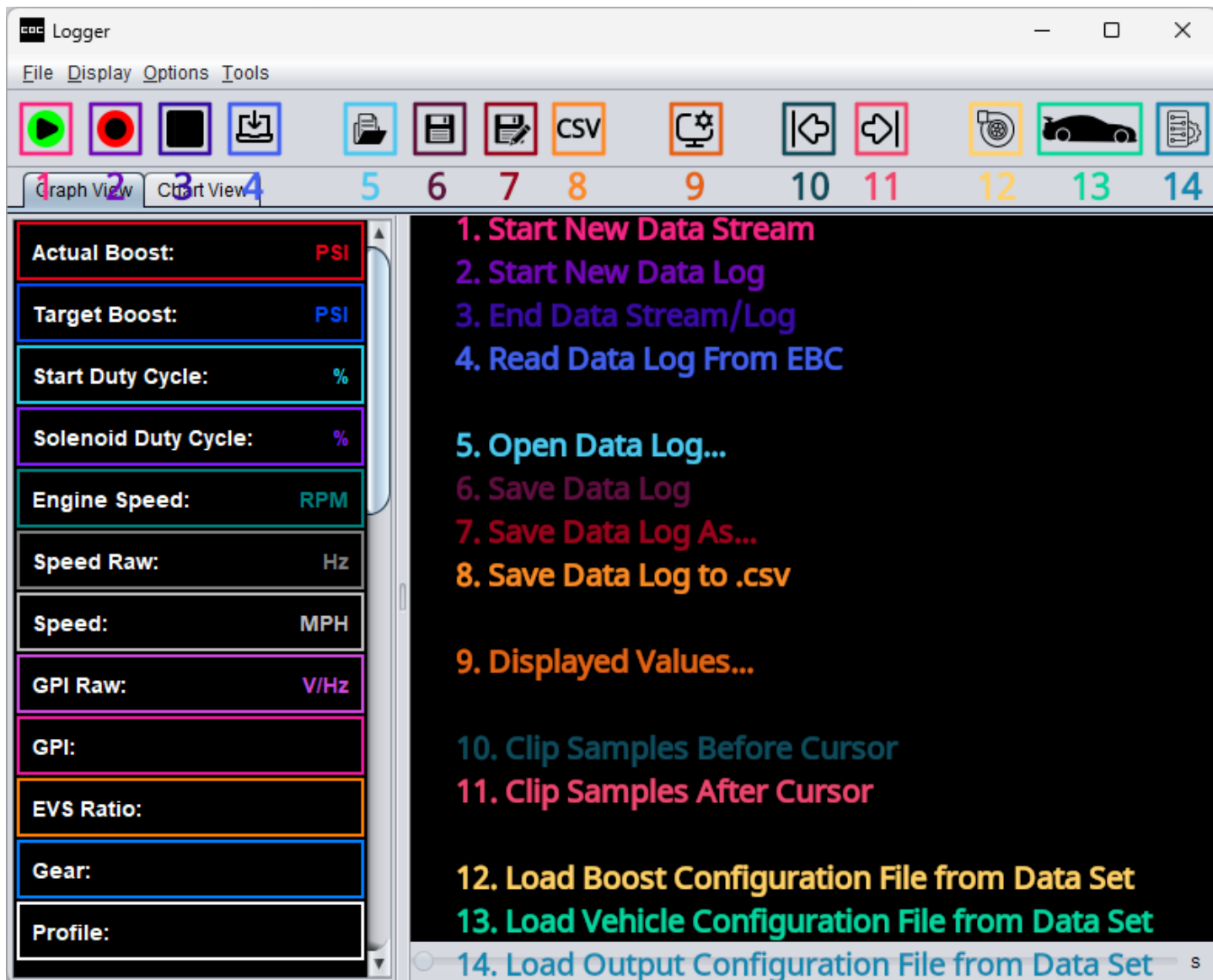

## DATA ACQUISITION

Data from the Cortex EBC can be collected in two modes:

- **Data Stream** – Data is collected but not automatically saved to a file.
- **Data Log** – Data is collected and automatically saved to a file on your computer. Each file is assigned a unique name based on the creation time, formatted as: **Run\_MM\_DD\_YYYY\_HH\_MM\_SS**.

## INTERNAL LOGGER

The internal logging function can be used to record data from the Cortex EBC without having a laptop in the car. The internal logger records a smaller data set compared to logs that are captured directly through the Cortex Config software, but there is still plenty of information to make educated changes to your boost control settings.

The logger is triggered by boost pressure and automatically stops after collecting 500 data samples, which equals 20 seconds of data at a 25 Hz boost control solenoid frequency. The activation boost threshold can be set to 0.5, 1.0, 1.5, 2.0, or 2.5 PSI. While the logger is collecting data, the decimal point after the third digit on the LED display will be on.

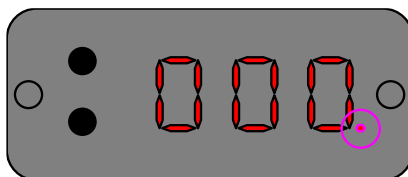

The Cortex EBC has memory space for a single log file, meaning any existing log data will be overwritten each time the logging function is activated. To prevent accidental data loss, it is crucial to disable the logging function after capturing a log or ensure that boost pressure remains below the activation threshold.

INTERNAL LOGGER PARAMETER	DIFFERENCES FROM LOGS CAPTURED IN SOFTWARE
Actual Boost	None
Target Boost	None
Start Duty Cycle	None
Solenoid Duty Cycle	None
Engine Speed	None
Speed	Limited to 255 MPH
GPI	None
Output 1	Integer value only (no decimal values)
Output 2	Integer value only (no decimal values)
Overboost Flag	None
GPI Fail-Safe Flag	None
Spool Flag	None
Transbrake Flag	None
Launch Flag	None
Scramble Flag	None
Bump Flag	None

See [this section](#) to learn how to enable the internal logging function.

## INPUT SIGNAL CONFIGURATION

The configuration settings for the Cortex EBC inputs are stored in a vehicle configuration file. Before adjusting boost with the Cortex EBC, you must first create a vehicle configuration file for your specific application.

Vehicle configuration files can only be modified using the Cortex Config software. For any changes to take effect, you must transfer the updated settings to the device by clicking the "Write" button at the bottom of the Vehicle Configuration window. Since some configuration settings depend on one another, you may need to transfer new settings multiple times to complete the process. In general, you should calibrate the RPM detection first, gear detection second, speed detection third, and the general-purpose input last.

To ensure accurate sensor readings, use the logger feature in the software to verify that the vehicle configuration file has been properly configured.

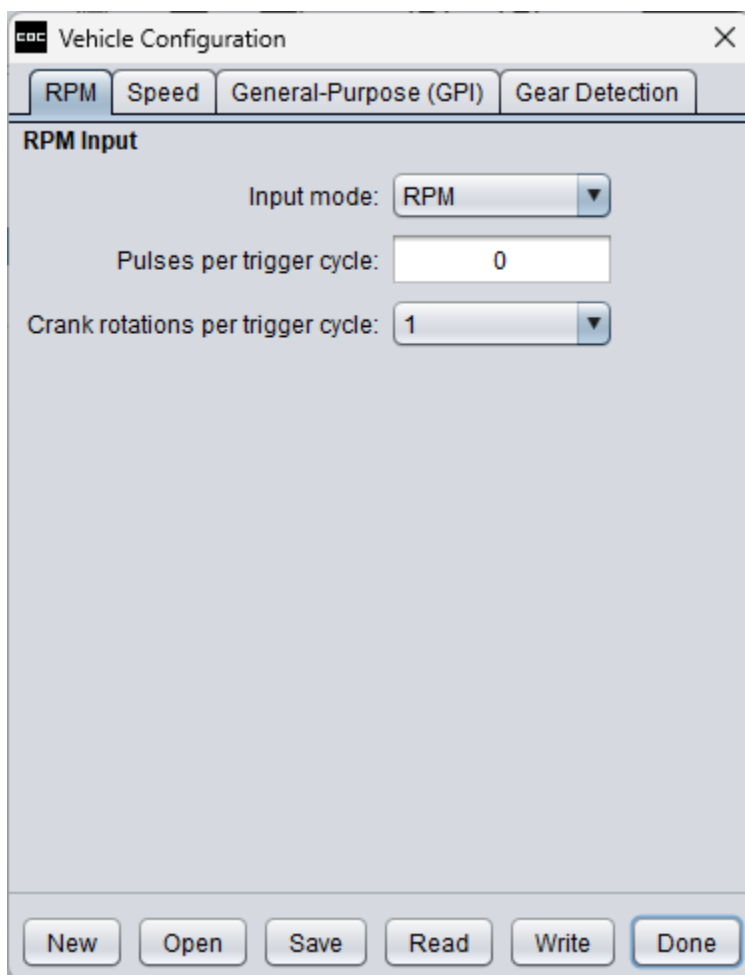

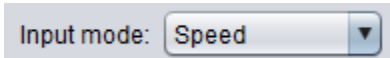
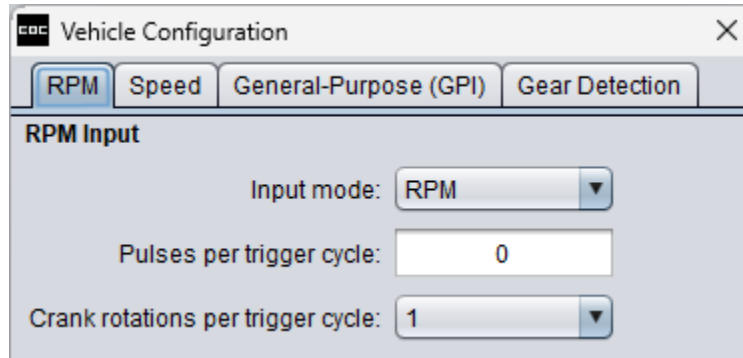

The **Input mode** field determines the operating mode for the RPM input.

- **RPM** – Use RPM input for engine speed detection.
- **Launch Low** – Use RPM input for launch boost control activation by switching to ground.
- **Launch High** – Use RPM input for launch boost control activation by switching to 12V.
- **Bump Box** – Use RPM input for transbrake bump control activation.
- **Scramble** – Use RPM input for boost scramble control activation.

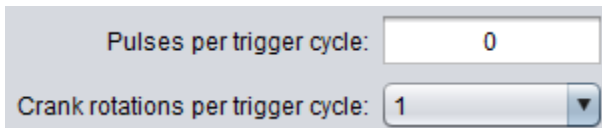

The **Pulses per trigger cycle** and **Crank rotations per trigger cycle** fields are used to calibrate engine speed calculations. Engine speed signals generate a specific sequence of trigger pulses during each trigger cycle. Depending on the signal type, a complete cycle of trigger pulses will be produced each time the crank makes one or two full revolutions. The Cortex EBC calculates engine speed by measuring the time required for a complete trigger cycle to be produced.

**Pulses per trigger cycle** – The number of pulses produced by the engine speed signal during each trigger cycle.

**Crank rotations per trigger cycle** – The number of crank rotations that occur during each trigger cycle (1 or 2).

Use the table on the following page to help determine the correct settings for your application.

## RPM CALIBRATION PROCEDURE

Use the table below to determine the appropriate values for the **Pulses per trigger cycle** and **Crank rotations per trigger cycle** fields based on the source of your engine speed signal. After entering these values, write the new Vehicle Configuration settings to the controller, and then use the logger to verify that the engine speed calculated by the Cortex EBC matches the actual engine speed.

RPM SIGNAL TYPE	PULSES PER TRIGGER CYCLE	CRANK ROTATIONS PER TRIGGER CYCLE
<b>Tach Signal</b>	Number of cylinders in engine *	2
<b>CB-2 CAN Bus Interface</b>	2 **	1
<b>Mustang / F-150 CAN Bus Interface</b>	4	1
<b>Crank Position Sensor</b>	Number of teeth on trigger wheel	1
<b>Cam Position Sensor</b>	Number of teeth on trigger wheel	2
<b>Fuel Injector Trigger ***</b>	1	2
<b>Distributor Trigger</b>	Number of cylinders in engine	2
<b>Waste-Spark Coil Trigger</b>	1	1
<b>Coil-on-Plug Trigger</b>	1	2

\* Set to 4 for all GM applications

\*\* 2018+ Fords: Set to 1 if calculated RPM is half of actual RPM

\*\*\* Port fuel injectors only

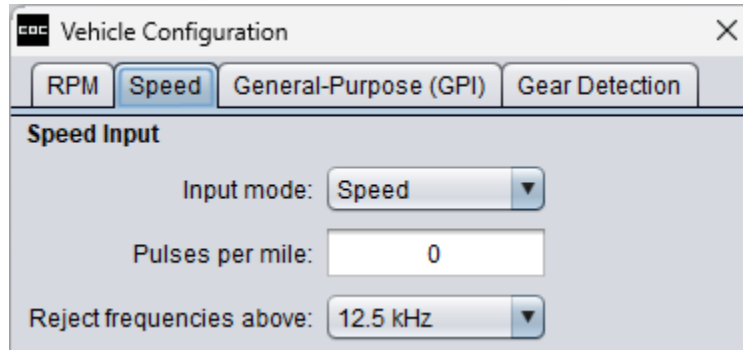

Input mode: Speed

**Input mode** – Determines the operating mode for the speed input.

- **Speed** – Use speed input for vehicle speed detection.
- **Launch Low** – Use speed input for launch boost control activation by switching to ground.
- **Launch High** – Use speed input for launch boost control activation by switching to 12V.
- **Bump Box** – Use speed input for transbrake bump control activation.
- **Scramble** – Use speed input for boost scramble control activation.

Pulses per mile: 0

The **Pulses per mile** field is used to calibrate vehicle speed calculations. For the Cortex EBC to accurately calculate vehicle speed this parameter needs to be set to match the number of pulses produced by your speed signal when the vehicle is driven for one mile. Common values include 2,000, 4,000, 6,000, and 8,000. Set to 3,600 for CB-2 Can Bus Interface.

An easy way to determine the pulses per mile produced by your vehicle speed signal is to drive at 30 MPH and monitor the raw speed value (Hz) on the device display or in the logger portion of the Cortex Config software. Multiply the speed signal frequency at 30 MPH by 120 to determine the correct pulses per mile setting for your application.

- If the calculated speed is lower than the actual speed: decrease pulses per mile
- If the calculated speed is higher than the actual speed: increase pulses per mile

Reject frequencies above: 12.5 kHz

The **Reject frequencies above** field is used to help smooth noisy speed signals by ignoring incoming pulses that exceed a certain frequency. This parameter can be left at 12.5 kHz for most applications and should only be reduced from 12.5 kHz if speed signal noise is causing issues with gear detection or boost control.

## SPEED CALIBRATION PROCEDURE

Before attempting to calibrate vehicle speed, verify that the **Input mode** field is set to 'Speed' and the **Reject frequencies above** field is set to '12.5 kHz' in the Speed tab of the Vehicle Configuration file.

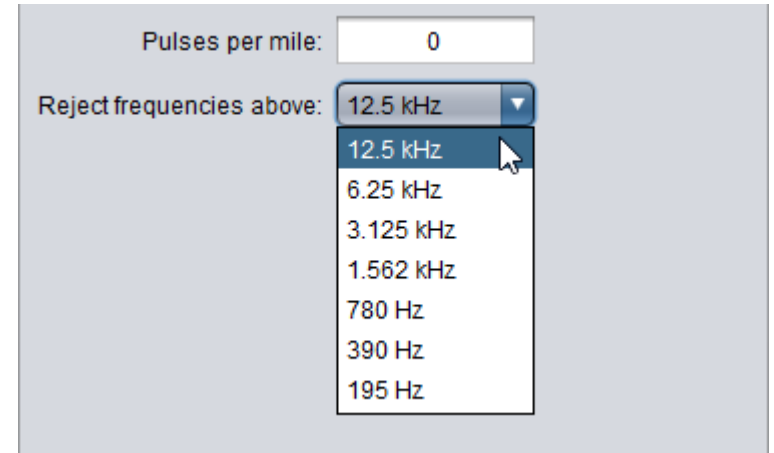
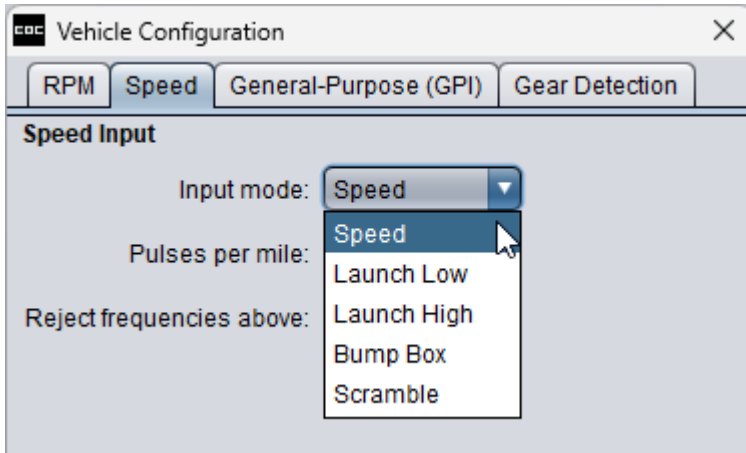

To determine the correct pulses per mile setting, monitor the value of the **Speed Raw** parameter in the logger while driving at 30 MPH and then multiply this number by 120. For example, the speed signal in the example log below outputs 133 Hz at 30 MPH. Therefore:

$$\text{Pulses per mile} = 133 \times 120 = 15960$$

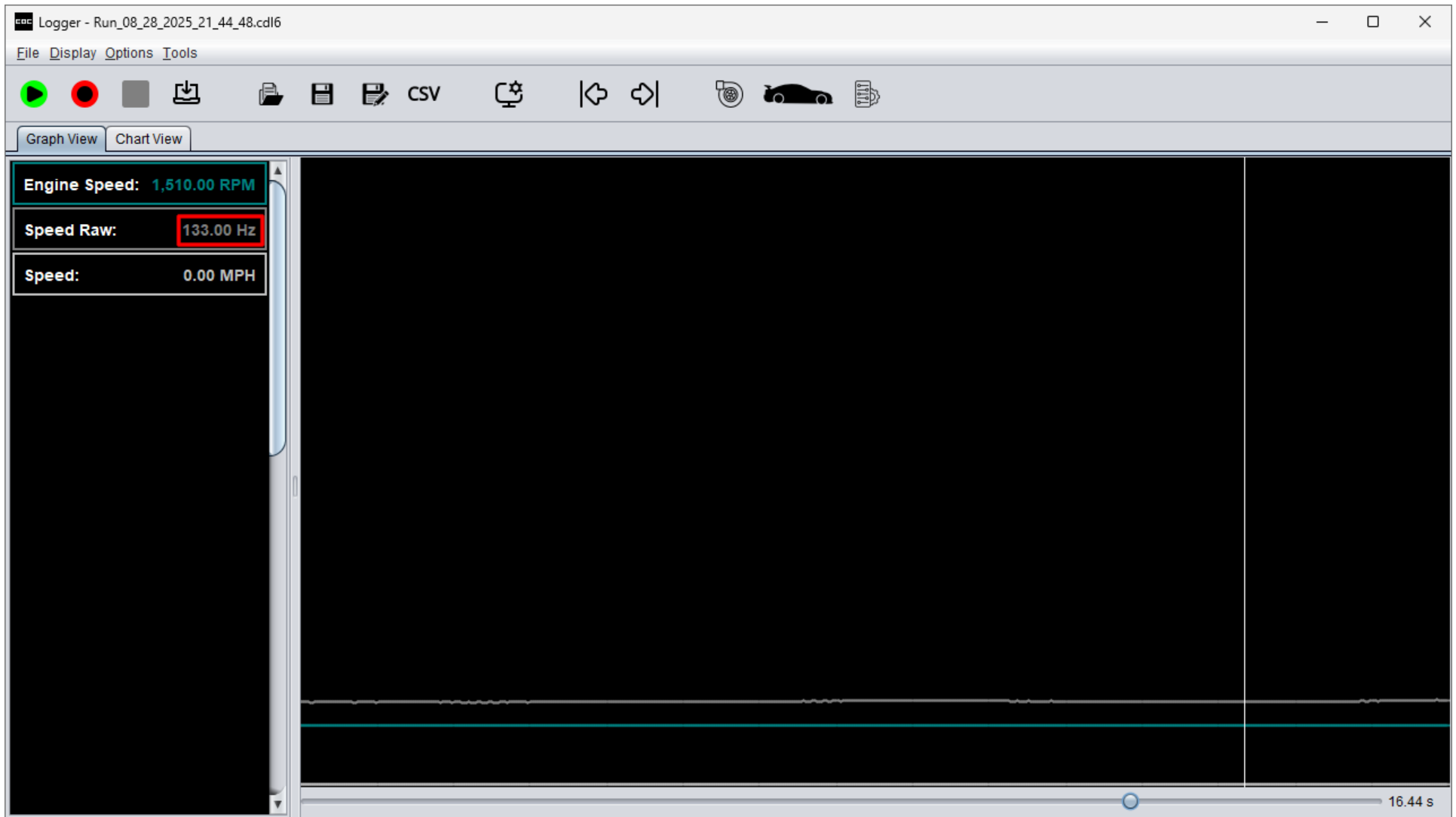

Input mode: Speed

Pulses per mile: 15960

Reject frequencies above: 12.5 kHz

Enter the calculated value into the **Pulses per mile** field in the Speed tab of the Vehicle Configuration window.

Write the new Vehicle Configuration settings to the controller and then use the logger to verify that the vehicle speed calculated by the Cortex EBC matches the actual vehicle speed.

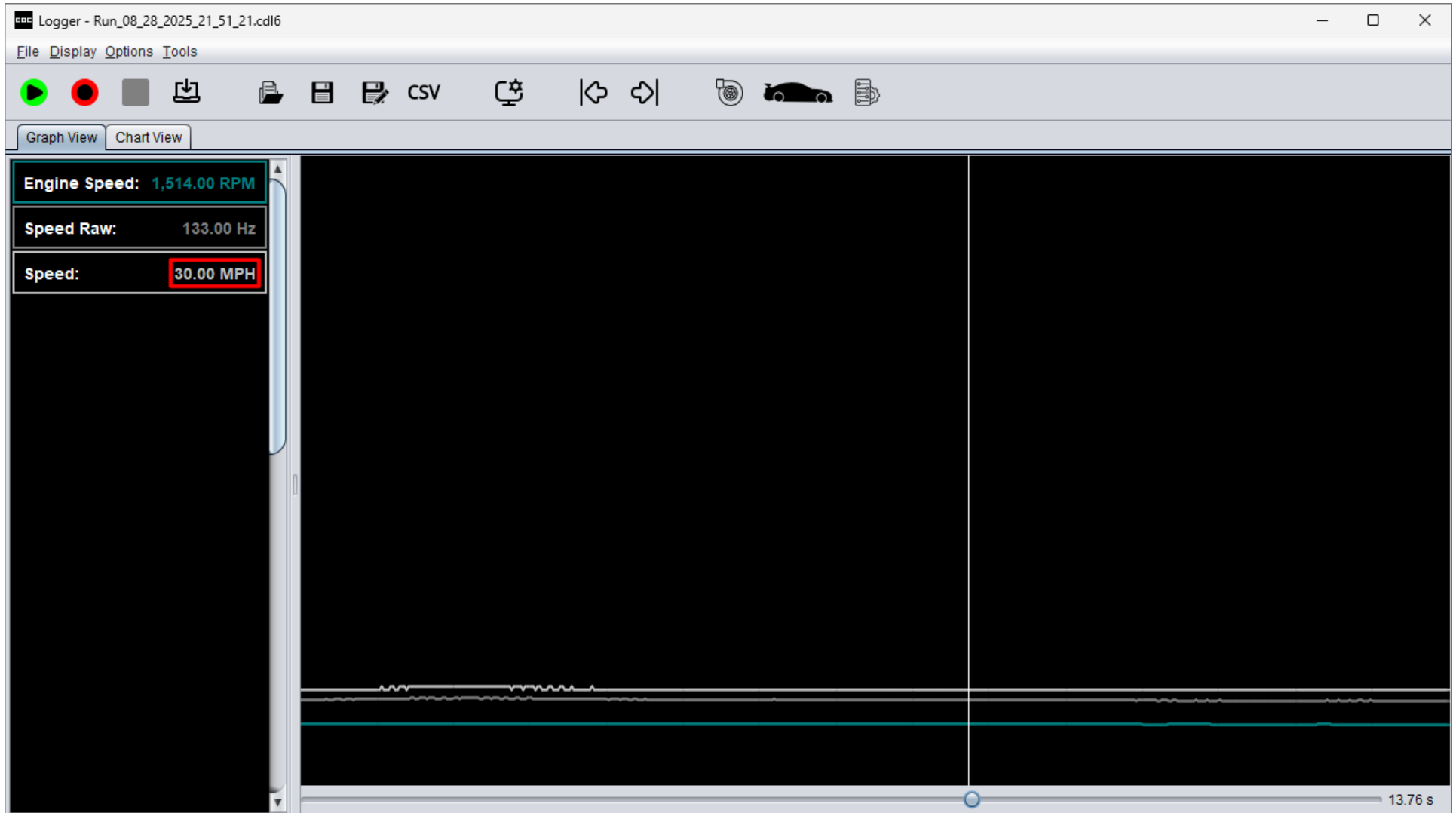

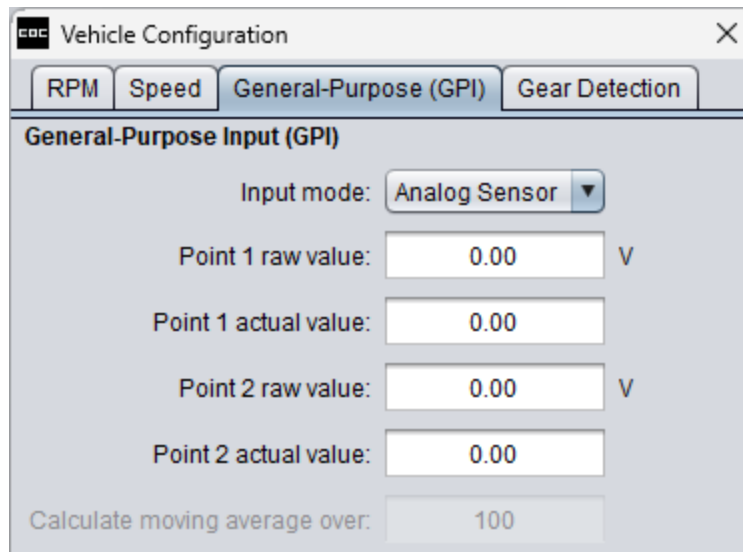

Input mode:

The **Input mode** field determines the operating mode for the general-purpose input.

- **Analog Sensor** – Use GPI for analog sensor input.
- **Digital Sensor** – Use GPI for digital sensor input.
- **Launch Low** – Use GPI for launch boost control activation by switching to ground.
- **Launch High** – Use GPI for launch boost control activation by switching to 12V.
- **Bump Box** – Use GPI for transbrake bump control activation.
- **Scramble** – Use GPI for boost scramble control activation.

Point 1 raw value:	<input type="text" value="0.00"/>	V
Point 1 actual value:	<input type="text" value="0.00"/>	
Point 2 raw value:	<input type="text" value="0.00"/>	V
Point 2 actual value:	<input type="text" value="0.00"/>	

The **Point 1 raw value**, **Point 1 actual value**, **Point 2 raw value**, and **Point 2 actual value** fields are used to calibrate analog and digital sensor readings from the general-purpose input. To calibrate a sensor, simply input the raw sensor value (V or Hz) and the corresponding scaled value (AFR, PSI, cc/min, etc.) from two separate data points. The min sensor output and max sensor output are typically used for the two data points. Field resolution is 0.01 for analog sensors and 1 for digital sensors.

Calculate moving average over:

The **Calculate moving average over** field sets the smoothing factor for readings from digital sensors. Setting this parameter to 1 will result in no smoothing. Setting this parameter to zero will prevent the Cortex EBC from calculating frequency on the general-purpose input.

## GPI CALIBRATION PROCEDURE

The table below provides calibration information for commonly used sensors.

SENSOR TYPE	INPUT MODE	POINT 1 RAW	POINT 1 ACTUAL	POINT 2 RAW	POINT 2 ACTUAL	MOVING AVERAGE
<b>THROTTLE POSITION</b>	Analog Sensor	Use Logger*	0.00	Use Logger*	100.00	N/A
<b>ETHANOL CONTENT</b>	Digital Sensor	50	0	150	100	100
<b>100 PSI PRESSURE</b>	Analog Sensor	0.50**	0.00	4.50**	100.00	N/A
<b>300 PSI PRESSURE</b>	Analog Sensor	0.50**	0.00	4.50**	300.00	N/A
<b>AQUAMIST FLOW</b>	Digital Sensor	0	0	400	2500	10
<b>VISION FLOW***</b>	Digital Sensor	0	0	880	2400	20
<b>INNOVATE WBO2</b>	Analog Sensor	0.00	7.35 AFR   0.5 λ	5.00	22.39 AFR   1.52 λ	N/A
<b>ZEITRONIX WBO2</b>	Analog Sensor	0.00	9.60 AFR   0.65 λ	5.00	19.60 AFR   1.33 λ	N/A
<b>AEM WBO2</b>	Analog Sensor	0.00	10.00 AFR   0.68 λ	5.00	19.98 AFR   1.36 λ	N/A
<b>AEM X-SERIES WBO2****</b>	Analog Sensor	0.50	8.50 AFR   0.58 λ	4.50	18.00 AFR   1.23 λ	N/A
<b>TSG-1 TURBO SPEED GAUGE</b>	Analog Sensor	0.00	0.00	5.00	200.00	N/A

\*Monitor the **GPI Raw** value in the logger with the throttle fully open and fully closed to obtain these values.

\*\*The output range of most pressure sensors is 0.50V-4.50V.

\*\*\*Vision Part Numbers BV1000TRN025A or BV1000TRN025B

\*\*\*\*Brown wire on WBO2 (Analog Negative -) must be connected to chassis ground for accurate readings.

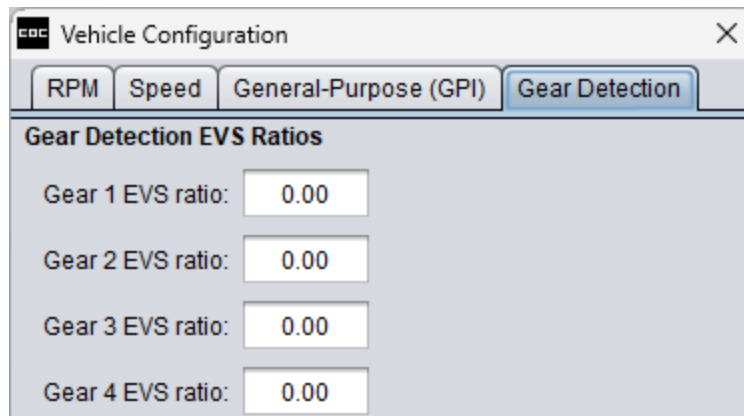

Gear 1 EVS ratio:

The **Gear X EVS ratio** fields set the comparison thresholds for the gear detection algorithm. The engine-to-vehicle speed (EVS) ratio is calculated by dividing engine speed (RPM) by raw speed sensor frequency (Hz).

The **Gear 1-10 EVS ratio** parameters should be set to match the EVS ratio calculated by the Cortex EBC while driving in each gear. This value can be viewed on the device display or in the logger portion of the Cortex Config software.

On vehicles with manual transmissions, the EVS ratio will be constant in each gear if the clutch is fully engaged.

On vehicles with automatic transmissions, the EVS ratio may have some variation in each gear depending on torque converter configuration, and the EVS ratios should be determined while accelerating with some boost pressure. Automatics utilizing a lock-up converter should determine EVS ratios while the lock-up clutch is engaged.

The gear detection works by comparing the EVS ratio settings for each gear to the real-time EVS ratio that is calculated as the vehicle moves down the road. The gear whose EVS ratio setting is closest to the real-time EVS will be deemed the active gear. For example, consider a 4-speed transmission with the following settings programmed to the Cortex EBC:

- Gear 1 EVS ratio setting: 200.00
- Gear 2 EVS ratio setting: 100.00
- Gear 3 EVS ratio setting: 50.00
- Gear 4 EVS ratio setting: 30.00

In this case the midpoint between gears 1 and 2 is 150.00, the midpoint between gears 2 and 3 is 75.00, and the midpoint between gears 3 and 4 is 40.00. Therefore, the controller will use the following EVS ratio ranges for each gear:

- Gear 1 EVS range: 150.01 and higher
- Gear 2 EVS range: 75.01-150.00
- Gear 3 EVS range: 40.01-75.00
- Gear 4 EVS range: 40.00 and lower

**WARNING:** Engine speed detection must be correctly calibrated before attempting to determine the EVS ratios settings for gear detection.

## GEAR DETECTION CALIBRATION PROCEDURE

For most applications, the easiest way to calibrate the gear detection is to start a data log while the vehicle is stationary. Then slowly accelerate, ensuring that you spend several seconds in each gear before ending the log. After capturing this data, arrange the main software window and the logger window so they are side by side on your screen.

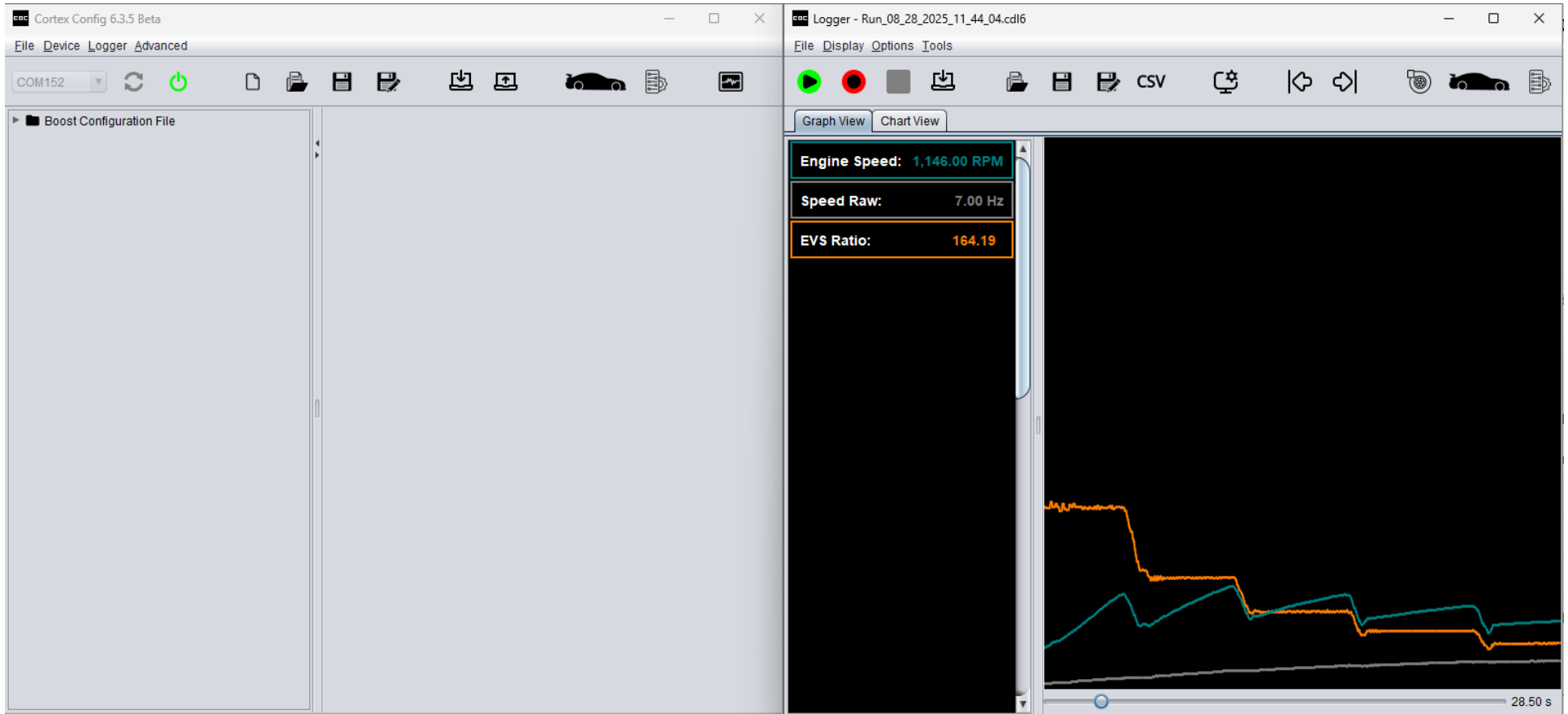

Open the Vehicle Configuration window and select the **Gear Detection** tab. Then, use the scroll bar in the lower portion of the logger window to move the sample cursor (white vertical line) to a point where you were driving in first gear. Enter the EVS Ratio value displayed by the logger at this point into the **Gear 1 EVS ratio** field in the Vehicle Configuration window (164.64 in this example). Ensure the point you pick is after the clutch has fully engaged and the EVS Ratio has flattened out.

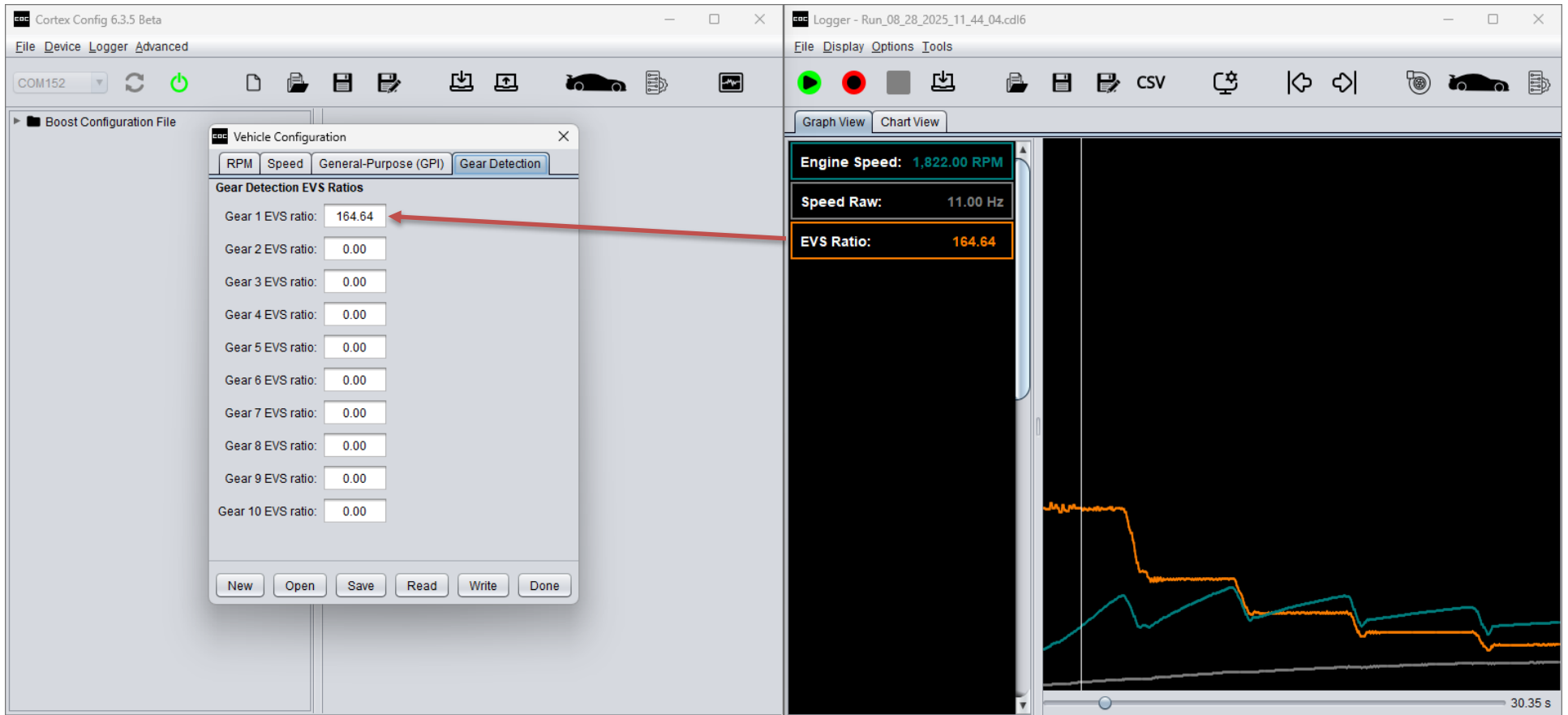

Continue scrolling through the log data to obtain the EVS ratio for every gear.

Gear 2 – 100.25

The image shows two software windows from the Cortex EBC system. The left window, titled 'Cortex Config 6.3.5 Beta', displays the 'Vehicle Configuration' dialog box with the 'Gear Detection' tab selected. The 'Gear Detection EVS Ratios' section lists ratios for gears 1 through 10. A red arrow points from the 'Gear 2 EVS ratio' field, which contains the value '100.25', to the right window. The right window, titled 'Logger - Run\_08\_28\_2025\_11\_44\_04.cdl6', shows real-time data. The 'EVS Ratio' is highlighted in orange and displays the value '100.25'. Below the data, a graph shows the EVS Ratio (orange line) and other parameters (teal and grey lines) over time. The graph shows a step change in the EVS Ratio, corresponding to the gear change. The time axis at the bottom right of the graph is labeled '35.25 s'.

Parameter	Value
Engine Speed	2,334.00 RPM
Speed Raw	23.00 Hz
EVS Ratio	100.25

Gear	EVS Ratio
Gear 1	164.64
Gear 2	100.25
Gear 3	0.00
Gear 4	0.00
Gear 5	0.00
Gear 6	0.00
Gear 7	0.00
Gear 8	0.00
Gear 9	0.00
Gear 10	0.00

Gear 3 – 68.68

The image shows two software windows side-by-side. The left window is 'Cortex Config 6.3.5 Beta' with the 'Gear Detection' tab selected in the 'Vehicle Configuration' dialog. It lists EVS ratios for gears 1 through 10, with Gear 3 set to 68.68. A red arrow points from this value to the right window. The right window is 'Logger - Run\_08\_28\_2025\_11\_44\_04.cdl6' in 'Chart View', displaying real-time data for Engine Speed (2,470.00 RPM), Speed Raw (36.00 Hz), and EVS Ratio (68.68). A graph below shows the historical data for these metrics over time, with a timestamp of 41.25 s.

Parameter	Value
Engine Speed	2,470.00 RPM
Speed Raw	36.00 Hz
EVS Ratio	68.68

Gear 4 – 51.32

The image shows two software windows from the Cortex EBC system. The left window, 'Cortex Config 6.3.5 Beta', displays the 'Vehicle Configuration' dialog box with the 'Gear Detection' tab selected. It lists 'Gear Detection EVS Ratios' for gears 1 through 10. A red arrow points from the 'Gear 4 EVS ratio' field, which contains the value '51.32', to the right window. The right window, 'Logger - Run\_08\_28\_2025\_11\_44\_04.cdl6', shows real-time data. A summary panel on the left of the logger displays 'Engine Speed: 2,208.00 RPM', 'Speed Raw: 43.00 Hz', and 'EVS Ratio: 51.32'. The 'EVS Ratio' value is highlighted with an orange border. Below the summary panel is a graph showing multiple data series over time, with a time indicator of 46.75 s at the bottom right.

Parameter	Value
Engine Speed	2,208.00 RPM
Speed Raw	43.00 Hz
EVS Ratio	51.32

Gear	EVS Ratio
Gear 1	164.64
Gear 2	100.25
Gear 3	68.68
Gear 4	51.32
Gear 5	0.00
Gear 6	0.00
Gear 7	0.00
Gear 8	0.00
Gear 9	0.00
Gear 10	0.00

Gear 5 – 39.60

The image shows two software windows. The left window is 'Cortex Config 6.3.5 Beta' with the 'Advanced' tab selected. It displays a 'Boost Configuration File' folder containing a 'Vehicle Configuration' dialog box. The 'Gear Detection' tab is active, showing 'Gear Detection EVS Ratios' for gears 1 through 10. A red arrow points from the 'Gear 5 EVS ratio' field, which contains the value '39.60', to the right window. The right window is 'Logger - Run\_08\_28\_2025\_11\_44\_04.cdl6' in 'Graph View'. It displays real-time data: 'Engine Speed: 1,885.00 RPM', 'Speed Raw: 48.00 Hz', and 'EVS Ratio: 39.60'. Below the data is a graph with three lines (orange, teal, and grey) and a time axis at the bottom showing '52.15 s'.

Parameter	Value
Engine Speed	1,885.00 RPM
Speed Raw	48.00 Hz
EVS Ratio	39.60

Gear	EVS Ratio
Gear 1	164.64
Gear 2	100.25
Gear 3	68.68
Gear 4	51.32
Gear 5	39.60
Gear 6	0.00
Gear 7	0.00
Gear 8	0.00
Gear 9	0.00
Gear 10	0.00

Write the new Vehicle Configuration settings to the controller and then use the logger to verify that the gear detected by the Cortex EBC matches the actual gear.

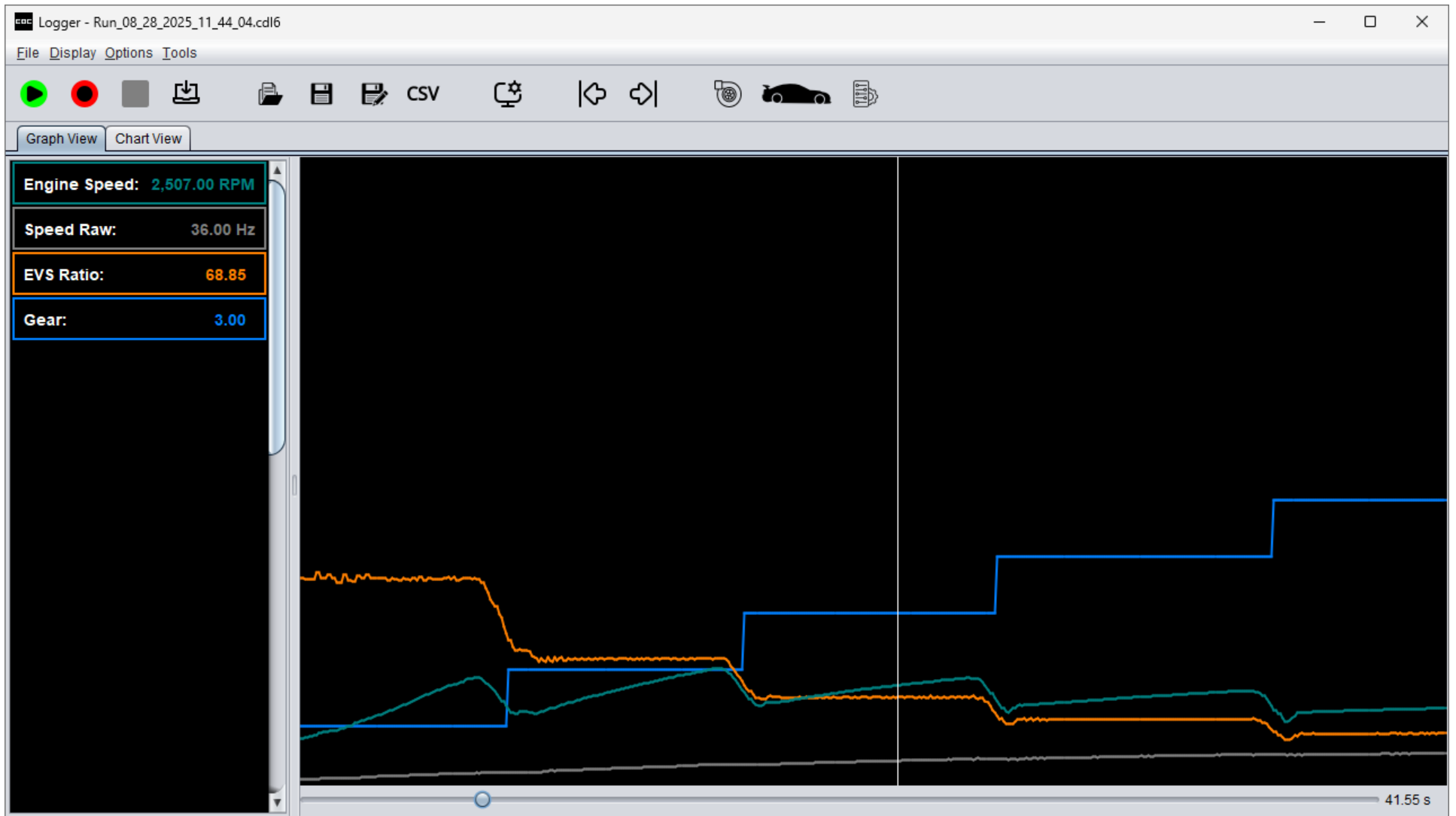

## BOOST CONTROL

The Cortex EBC controls boost by rapidly pulsing a 3-Port or 4-Port boost control solenoid (BCS) to manipulate the pressure applied to one or more ports on your wastegate(s). The BCS is always pulsed at a constant frequency, but the duration of each pulse can be continuously modulated to control the overall amount of air that passes through the solenoid. This control method is commonly known as pulse width modulation (PWM).

The duty cycle of the PWM control signal is the percentage of time that the BCS will be powered during each on-off cycle. At 0% duty cycle, the BCS will be off for the entire cycle. At 50% duty cycle, the BCS will be on for half of the cycle and off for the other half. At 100% duty cycle, the BCS will be on for the entire cycle.

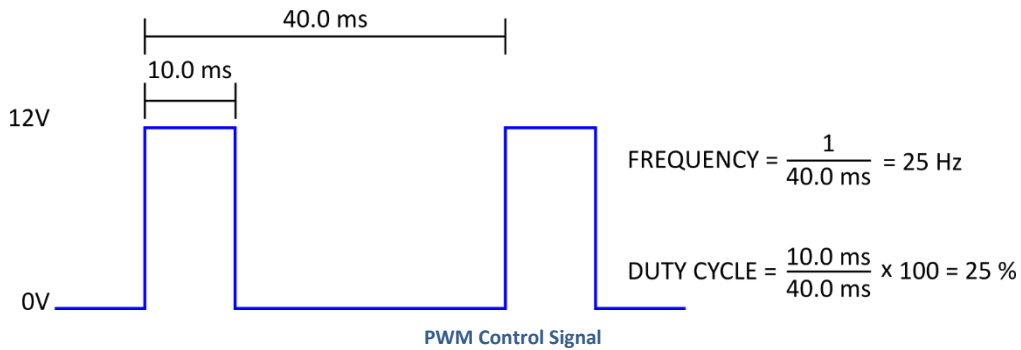

Setting boost with the Cortex EBC is an iterative process that involves adjusting various boost control parameters until the PWM duty cycle applied to the BCS generates the desired boost curve. Generally, increasing the BCS duty cycle results in the turbo producing more boost, as illustrated in the diagram below.

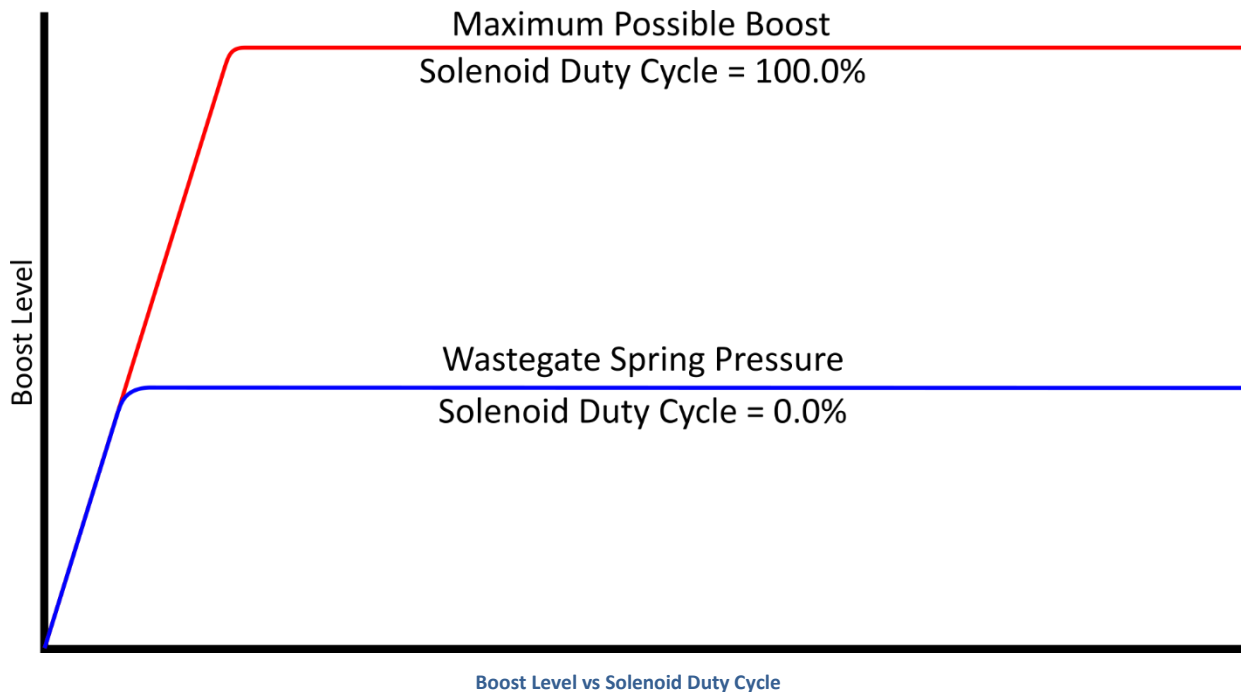

The boost level produced at a specific duty cycle depends on numerous factors, including wastegate spring pressure, gear, engine speed, exhaust manifold backpressure, and ambient weather conditions. In an ideal turbo system, applying a static duty cycle will result in a stable boost level from spool-up to redline. However, in most real-world setups, the duty cycle must be constantly adjusted throughout the powerband to obtain a stable boost curve.

## BOOST CONTROL SETTINGS

The boost control settings for the Cortex EBC are stored within a boost configuration file. These files can only be modified using the Cortex Config software. For any changes to take effect, you must transfer the updated settings to the device by clicking the write button at the top of the software window.

Each boost configuration file contains 6 unique boost control profiles that can be selected on the fly using the buttons on the front of the Cortex EBC device. The settings in each profile are broken into 5 categories:

- [Configuration](#)
- [Open-Loop](#)
- [Closed-Loop](#)
- [Launch](#)
- [Fail-Safes](#)

---

## CONFIGURATION

### CONFIGURATION: PROFILE CONFIGURATION

The profile configuration settings determine the boost control strategy that will be used when the corresponding profile is selected for boost control.

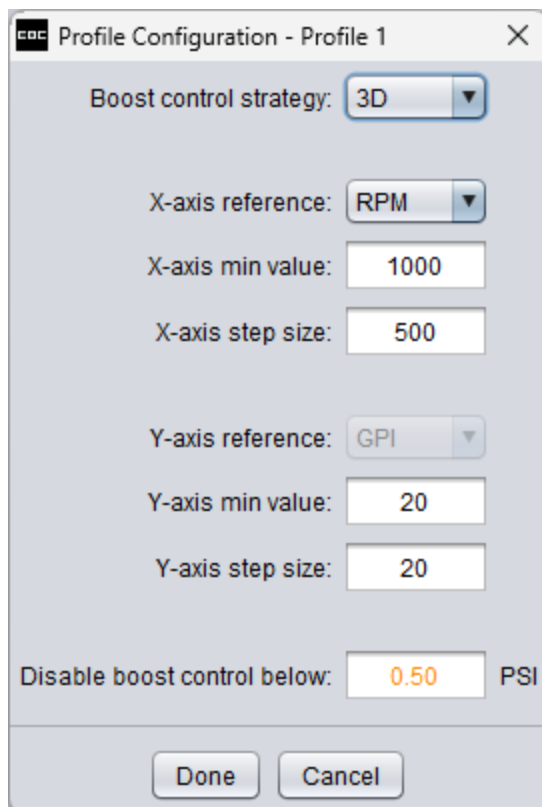

The screenshot shows a dialog box titled "Profile Configuration - Profile 1". It contains the following settings:

- Boost control strategy: 3D (dropdown menu)
- X-axis reference: RPM (dropdown menu)
- X-axis min value: 1000 (text input)
- X-axis step size: 500 (text input)
- Y-axis reference: GPI (dropdown menu)
- Y-axis min value: 20 (text input)
- Y-axis step size: 20 (text input)
- Disable boost control below: 0.50 PSI (text input)

At the bottom of the dialog are "Done" and "Cancel" buttons.

Boost control strategy: Basic ▼

The **Boost control strategy** field sets the general method of boost control that will be used in the corresponding boost control profile.

Gear based boost control is possible with any control strategy except for **2D x 16** or **2D x 64** referenced to time.

- **Basic** – Boost control based on gear only.
- **2D x 16** – Boost control based on 16-cell 2D tables.
- **2D x 64** – Boost control based on 64-cell 2D tables.
- **3D** – Boost control based on 16x4 cell 3D tables.

X-axis reference: RPM ▼

The **X-axis reference** field sets the type of data that will be referenced by the x-axis of the boost control tables when using the 3D boost control strategy. Possible data types are RPM and Speed.

X-axis min value: 1,000  
X-axis step size: 500

The **X-axis min value** and **X-axis step size** fields set the control point scaling of the x-axis for 3D boost control tables. The first parameter sets the value of the initial control point, and the second parameter sets the spacing between all the subsequent control points.

**NOTE:** The first and last control points will continue to be used for boost control in situations that are outside of the axis bounds.

Y-axis reference: RPM ▼

The **Y-axis reference** field sets the type of data that will be referenced by the y-axis of the boost control tables when using the 2D or 3D boost control strategies. Possible data types for the 2D boost control strategies are RPM, Speed, GPI (General-Purpose Input), or Time. The 3D boost control strategy will always reference GPI data.

Y-axis min value: 1,000  
Y-axis step size: 500

The **Y-axis min value** and **Y-axis step size** fields set the control point scaling of the y-axis for 2D and 3D boost control tables. The first parameter sets the value of the initial control point, and the second parameter sets the spacing between all the subsequent control points.

**NOTE:** The first and last control points will continue to be used for boost control in situations that are outside of the axis bounds.

Disable boost control below: 0.50 PSI

The **Disable boost control below** field sets the boost threshold under which boost control will be constantly disabled. This is also the boost level that must be reached for the GPI boost control fail-safes to deactivate and reset. In most cases, this parameter should be set to a value between 0.10-0.50 PSI.

**WARNING:** This parameter should only be set to zero to diagnosis the operation of the boost control solenoid.

# CONFIGURATION EXAMPLE – Basic Boost by Gear Strategy

One control point per gear

**Profile Configuration - Profile 1**

Boost control strategy: **Basic**

X-axis reference: **RPM**

X-axis min value: **1000**

X-axis step size: **500**

Y-axis reference: **RPM**

Y-axis min value: **1000**

Y-axis step size: **500**

Disable boost control below: **0.50** PSI

**Done** **Cancel**

**Cortex Config 6.3.5 Beta**

File Device Logger Advanced

COM152

Boost Configuration File

- Profile 1 - Basic Strategy
  - Configuration
  - Open-Loop
    - Start Duty Cycle**
      - Spool Boost Control
      - Gear Change Overboost Control
    - Closed-Loop
    - Launch
    - Fail-Safes
  - Profile 2 - Basic Strategy
  - Profile 3 - Basic Strategy
  - Profile 4 - Basic Strategy
  - Profile 5 - Basic Strategy
  - Profile 6 - Basic Strategy

**PROFILE: 1 | START DUTY CYCLE [ % ]**

1.00 Copy Paste Interpolate

	Start Duty Cycle (%)
Scramble	0.0
Gear 10	0.0
Gear 9	0.0
Gear 8	0.0
Gear 7	0.0
Gear 6	0.0
Gear 5	0.0
Gear 4	0.0
Gear 3	0.0
Gear 2	0.0
Gear 1	0.0

CONFIGURATION EXAMPLE – 16-point Boost by RPM Strategy  
 1,000-8,500 RPM control range, 500 RPM resolution

**Profile Configuration - Profile 1**

Boost control strategy: **2D x 16**

X-axis reference: **RPM**

X-axis min value: **1000**

X-axis step size: **500**

Y-axis reference: **RPM**

Y-axis min value: **1000**

Y-axis step size: **500**

Disable boost control below: **0.50** PSI

**Done** **Cancel**

Cortex Config 6.3.5 Beta

File Device Logger Advanced

COM152

Boost Configuration File

- Profile 1 - 2D RPM x 16 Strategy
  - Configuration
  - Fail-Safes
  - Launch
  - Open-Loop
    - Start Duty Cycle
      - Start Duty Cycle - Gear 1**
      - Start Duty Cycle - Gear 2
      - Start Duty Cycle - Gear 3
      - Start Duty Cycle - Gear 4
      - Start Duty Cycle - Gear 5
      - Start Duty Cycle - Gear 6
      - Start Duty Cycle - Gear 7
      - Start Duty Cycle - Gear 8
      - Start Duty Cycle - Gear 9
      - Start Duty Cycle - Gear 10
      - Start Duty Cycle - Scramble
    - Spool Boost Control
    - Gear Change Overboost Control
  - Closed-Loop
- Profile 2 - Basic Strategy
- Profile 3 - Basic Strategy
- Profile 4 - Basic Strategy
- Profile 5 - Basic Strategy
- Profile 6 - Basic Strategy

PROFILE: 1 | GEAR: 1 | START DUTY CYCLE [ % ]

1.00 Copy Paste Interpolate

	Start Duty Cycle (%)
8500 RPM	0.0
8000 RPM	0.0
7500 RPM	0.0
7000 RPM	0.0
6500 RPM	0.0
6000 RPM	0.0
5500 RPM	0.0
5000 RPM	0.0
4500 RPM	0.0
4000 RPM	0.0
3500 RPM	0.0
3000 RPM	0.0
2500 RPM	0.0
2000 RPM	0.0
1500 RPM	0.0
1000 RPM	0.0

CONFIGURATION EXAMPLE – 16-point Boost by Speed Strategy  
0-150 MPH control range, 10 MPH resolution.

**Profile Configuration - Profile 1**

Boost control strategy: **2D x 16**

X-axis reference: **RPM**

X-axis min value: **1000**

X-axis step size: **500**

Y-axis reference: **Speed**

Y-axis min value: **0**

Y-axis step size: **10**

Disable boost control below: **0.50** PSI

**Done** **Cancel**

**Cortex Config 6.3.5 Beta**

File Device Logger Advanced

COM152

**Boost Configuration File**

- ▼ Profile 1 - 2D MPH x 16 Strategy
  - ▶ Configuration
  - ▶ Fail-Safes
  - ▶ Launch
  - ▼ Open-Loop
    - ▼ Start Duty Cycle
      - Start Duty Cycle - Gear 1**
      - Start Duty Cycle - Gear 2
      - Start Duty Cycle - Gear 3
      - Start Duty Cycle - Gear 4
      - Start Duty Cycle - Gear 5
      - Start Duty Cycle - Gear 6
      - Start Duty Cycle - Gear 7
      - Start Duty Cycle - Gear 8
      - Start Duty Cycle - Gear 9
      - Start Duty Cycle - Gear 10
      - Start Duty Cycle - Scramble
    - Spool Boost Control
    - Gear Change Overboost Control
  - ▶ Closed-Loop
  - ▶ Profile 2 - Basic Strategy
  - ▶ Profile 3 - Basic Strategy
  - ▶ Profile 4 - Basic Strategy
  - ▶ Profile 5 - Basic Strategy
  - ▶ Profile 6 - Basic Strategy

**PROFILE: 1 | GEAR: 1 | START DUTY CYCLE [ % ]**

1.00 : Copy Paste Interpolate

	Start Duty Cycle (%)
150 MPH	0.0
140 MPH	0.0
130 MPH	0.0
120 MPH	0.0
110 MPH	0.0
100 MPH	0.0
90 MPH	0.0
80 MPH	0.0
70 MPH	0.0
60 MPH	0.0
50 MPH	0.0
40 MPH	0.0
30 MPH	0.0
20 MPH	0.0
10 MPH	0.0
0 MPH	0.0

CONFIGURATION EXAMPLE – 64-point Boost by Time Strategy  
 0.0-6.3 seconds control range, 100 millisecond resolution

**Profile Configuration - Profile 1**

Boost control strategy: 2D x 64

X-axis reference: RPM

X-axis min value: 1000

X-axis step size: 500

Y-axis reference: Time

Y-axis min value: 0

Y-axis step size: 100

Disable boost control below: 0.50 PSI

Done Cancel

Cortex Config 6.3.5 Beta

File Device Logger Advanced

COM152

Boost Configuration File

- Profile 1 - 2D Time x 64 Strategy
  - Configuration
  - Fail-Safes
  - Launch
  - Open-Loop
    - Start Duty Cycle
      - Start Duty Cycle - Primary
      - Start Duty Cycle - Scramble
  - Closed-Loop
- Profile 2 - Basic Strategy
- Profile 3 - Basic Strategy
- Profile 4 - Basic Strategy
- Profile 5 - Basic Strategy
- Profile 6 - Basic Strategy

PROFILE: 1 | PRIMARY | START DUTY CYCLE [%]

1.00 Copy Paste Interpolate

	Start Duty Cycle (%)
6.3 s	0.0
6.2 s	0.0
6.1 s	0.0
6.0 s	0.0
5.9 s	0.0
5.8 s	0.0
5.7 s	0.0
5.6 s	0.0
5.5 s	0.0
5.4 s	0.0
5.3 s	0.0
5.2 s	0.0
5.1 s	0.0
5.0 s	0.0
4.9 s	0.0
4.8 s	0.0
4.7 s	0.0
4.6 s	0.0
4.5 s	0.0
4.4 s	0.0

CONFIGURATION EXAMPLE – 3D RPM + Ethanol Content Strategy

RPM: 1,000-8,500 RPM control range, 500 RPM resolution

Ethanol Content: 55-85% control range, 10% resolution

**Profile Configuration - Profile 1**

Boost control strategy: **3D**

X-axis reference: **RPM**

X-axis min value: **1000**

X-axis step size: **500**

Y-axis reference: **GPI**

Y-axis min value: **55**

Y-axis step size: **10**

Disable boost control below: **0.50** PSI

**Done** **Cancel**

Cortex Config 6.3.5 Beta

File Device Logger Advanced

COM152

Boost Configuration File

- Profile 1 - 3D RPM + GPI Strategy
  - Configuration
  - Fail-Safes
  - Launch
  - Open-Loop
    - Start Duty Cycle
      - Start Duty Cycle - Gear 1**
      - Start Duty Cycle - Gear 2
      - Start Duty Cycle - Gear 3
      - Start Duty Cycle - Gear 4
      - Start Duty Cycle - Gear 5
      - Start Duty Cycle - Gear 6
      - Start Duty Cycle - Gear 7
      - Start Duty Cycle - Gear 8
      - Start Duty Cycle - Gear 9
      - Start Duty Cycle - Gear 10
      - Start Duty Cycle - Scramble
    - Spool Boost Control
    - Gear Change Overboost Control
  - Closed-Loop
- Profile 2 - Basic Strategy
- Profile 3 - Basic Strategy
- Profile 4 - Basic Strategy
- Profile 5 - Basic Strategy
- Profile 6 - Basic Strategy

**PROFILE: 1 | GEAR: 1 | START DUTY CYCLE [%]**

+ - X = 1.00 Copy Paste Interpolate

	Engine Speed (RPM)															
	1000	1500	2000	2500	3000	3500	4000	4500	5000	5500	6000	6500	7000	7500	8000	8500
85	0.0	0.0	0.0	0.0	0.0	0.0	0.0	0.0	0.0	0.0	0.0	0.0	0.0	0.0	0.0	0.0
75	0.0	0.0	0.0	0.0	0.0	0.0	0.0	0.0	0.0	0.0	0.0	0.0	0.0	0.0	0.0	0.0
65	0.0	0.0	0.0	0.0	0.0	0.0	0.0	0.0	0.0	0.0	0.0	0.0	0.0	0.0	0.0	0.0
55	0.0	0.0	0.0	0.0	0.0	0.0	0.0	0.0	0.0	0.0	0.0	0.0	0.0	0.0	0.0	0.0

Start Duty Cycle (%)

Engine Speed (RPM)

## OPEN-LOOP

Open-loop boost control is a method where you specify the exact duty cycle the controller should apply to the boost control solenoid (e.g., 60% duty cycle at 5,500 RPM in 3rd gear). With this approach, the controller does not make additional adjustments to the duty cycle to reach a specific target boost level. In many cases, this method can deliver excellent boost control, and closed-loop control is not necessary.

### OPEN-LOOP: START DUTY CYCLE

The start duty cycle is the most critical boost control parameter, as it determines the duty cycle applied to the boost control solenoid in most situations. Depending on the chosen boost control strategy, the start duty cycle can be uniquely set at 16 points in total, 64 points in total, 1 point per gear, 16 points per gear, or 64 points per gear.

**Using the start duty cycle tables is mandatory in all cases. You must adjust the start duty cycle tables to bring your boost level close to your target before enabling the closed-loop control.**

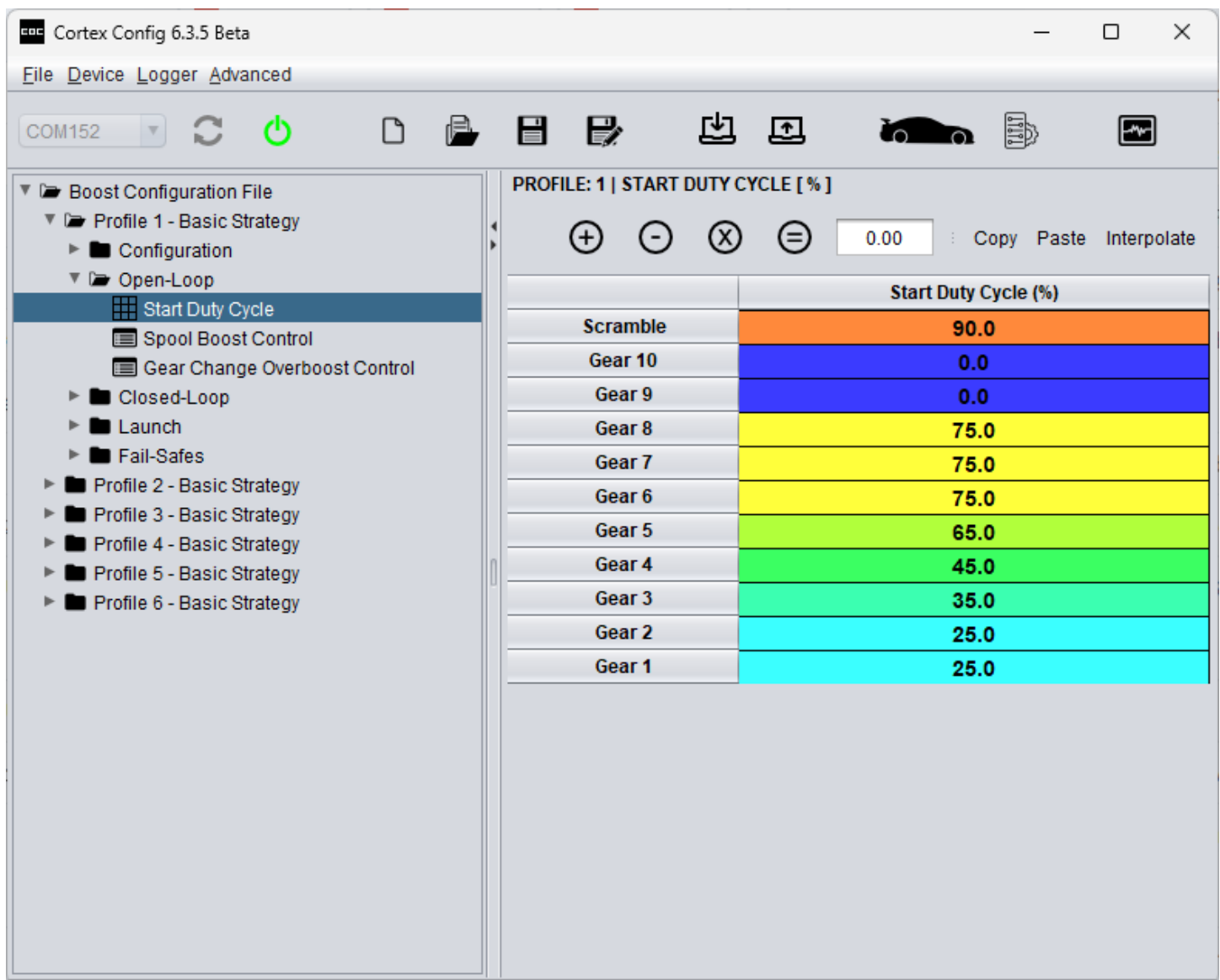

The screenshot shows the Cortex Config 6.3.5 Beta software interface. The left sidebar displays a tree view of configuration files, with 'Start Duty Cycle' selected under 'Open-Loop'. The main window displays a table titled 'PROFILE: 1 | START DUTY CYCLE [%]' with a control bar above it. The control bar includes a numeric input field set to '0.00' and buttons for '+', '-', 'X', '=', 'Copy', 'Paste', and 'Interpolate'. The table lists duty cycle percentages for various gear stages.

	Start Duty Cycle (%)
Scramble	90.0
Gear 10	0.0
Gear 9	0.0
Gear 8	75.0
Gear 7	75.0
Gear 6	75.0
Gear 5	65.0
Gear 4	45.0
Gear 3	35.0
Gear 2	25.0
Gear 1	25.0

When using the basic boost control strategy, you can only set the start duty cycle at one point per gear. In many cases, applying a static duty cycle in each gear will not produce a flat boost curve from turbo spool-up to redline. Instead, the boost level may increase (creep) or decrease (taper) as engine speed rises. Small amounts of boost creep or taper can typically be corrected using the closed-loop boost control function. However, significant boost creep or taper can only be addressed by switching to an RPM or vehicle-speed-based control strategy. These strategies allow the start duty cycle to be set at multiple points across the powerband, helping to stabilize the boost curve.

### General Procedure for Adjusting Start Duty Cycle:

- 1. Begin with a Start Duty Cycle of 20%**

There is typically no significant boost increase below this level.

- 2. Gradually Increase the Start Duty Cycle**

Increase the start duty cycle in small increments until the peak boost reaches your desired level. Initially, limit adjustments to increments of 5% or less. Once you gain familiarity with how your turbo system responds to different duty cycle levels, you can make larger adjustments as needed.

**OVERBOOST WARNING:** Excessive boost pressure can lead to catastrophic engine damage. Always make sure the overboost fail-safe parameters are set to an appropriate level before you attempt to increase boost above spring pressure.

**4-PORT BCS WARNING:** Extra care should be taken when making duty cycle adjustments if you are using a 4-port BCS. Because of the way these solenoids apply pressure to the wastegate, boost control can become extremely sensitive to changes in duty cycle. At higher duty cycle levels, it is not uncommon to see a 1-2 PSI change in boost pressure from a 1% change in duty cycle.

---

### OPEN-LOOP: SPOOL BOOST CONTROL

The spool boost control function is designed to reduce the time required to reach full boost. When building boost, wastegate(s) may begin to crack open several PSI before full boost is achieved. This allows some exhaust gas to escape through the wastegate instead of driving the turbocharger, increasing the time needed to reach full boost. The spool boost control function can be used to address this by temporarily applying a high static duty cycle to the boost control solenoid to prevent the wastegate(s) from opening prematurely.

Typically, the spool boost control function activates when manifold pressure transitions from vacuum to boost. It remains active until boost either exceeds the specified threshold or drops back to 0 PSI. However, its behavior can vary depending on the parameters being used.

Results from the spool boost control function depend on the specific application. Some turbo systems may experience a significant improvement in spool time, while others may see minimal improvement or encounter unacceptable boost spikes. If a substantial reduction in spool time is not observed, it is recommended to leave this function disabled.

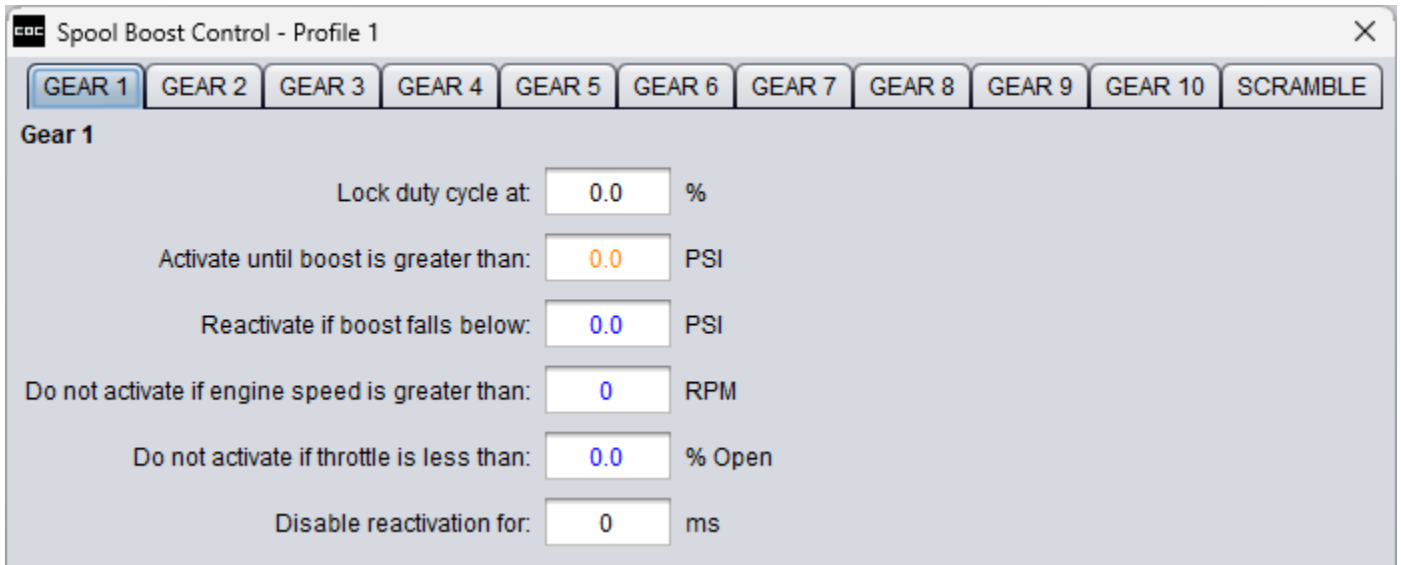

Lock duty cycle at:  %

The **Lock duty cycle at** field sets the constant duty cycle that will be used while the spool boost control is activated. In general, this field should be set to a very high value (100%) to ensure the wastegate valve is forced closed. If this field is set to zero it will cause the controller to continue using the start duty cycle tables, but the closed-loop boost control will be disabled until the spool boost control is deactivated.

Activate until boost is greater than:  PSI

The **Activate until boost is greater than** field sets the boost threshold under which the spool boost control will be activated. Setting this threshold to zero will disable the spool boost control function in the corresponding gear.

Reactivate if boost falls below:  PSI

The **Reactivate if boost falls below** field sets the boost threshold under which the spool boost control can reactivate during a gear change. This parameter should be used if boost does not drop to 0.0 PSI during a gear change, but you would like the spool control logic to reactivate. If this threshold is set to zero it will be ignored by the spool boost control activation logic.

Do not activate if engine speed is greater than:  RPM

The **Do not activate if engine speed is greater than** field sets the RPM threshold under which the spool boost control can activate. If this threshold is set to zero it will be ignored by the spool boost control activation logic.

Do not activate if throttle is less than:  % Open

The **Do not activate if throttle is less than** field sets the throttle position threshold over which the spool boost control can activate. This parameter can be used to substantially increase drivability at low throttle angles on vehicles that see a lot of street use. If this threshold is set to zero it will be ignored by the spool boost control activation logic.

**NOTE:** A throttle position signal must be connected to the general-purpose input to use this threshold.

Disable reactivation for:  ms

The **Disable reactivation for** field sets the amount of time that must pass before the spool boost control can be reactivated after boost drops to 0.0 PSI. This parameter can prevent the overshoot that can occur if a high duty cycle is applied in transient boost conditions (immediately respooling after a high RPM shift).

CONFIGURATION EXAMPLE:

The example settings below will lock duty cycle at 100% until boost reaches 12.0 PSI in 1<sup>st</sup> gear.

The screenshot shows a software window titled "Spool Boost Control - Profile 1" with a close button (X) in the top right corner. Below the title bar is a row of tabs labeled "GEAR 1", "GEAR 2", "GEAR 3", "GEAR 4", "GEAR 5", "GEAR 6", "GEAR 7", "GEAR 8", "GEAR 9", "GEAR 10", and "SCRAMBLE". The "GEAR 1" tab is selected. Underneath, the text "Gear 1" is displayed. The configuration area contains several settings, each with a text label, a numerical input field, and a unit:

- Lock duty cycle at:  %
- Activate until boost is greater than:  PSI
- Reactivate if boost falls below:  PSI
- Do not activate if engine speed is greater than:  RPM
- Do not activate if throttle is less than:  % Open
- Disable reactivation for:  ms

At the bottom of the window, there are two buttons: "Done" and "Cancel".

## OPEN-LOOP: GEAR CHANGE OVERBOOST CONTROL

Vehicles with dual-clutch transmissions (DCT) may experience significant boost spikes during gear shifts. The gear change overboost control function helps mitigate these spikes by predicting when a gear change is about to occur and temporarily overriding normal boost control. When activated, this function locks the duty cycle at a static value for a set duration, helping to stabilize boost levels during the gear change.

The screenshot shows a configuration window titled "Gear Change Overboost Control - Profile 1". At the top, there are tabs for GEAR 1 through GEAR 9, with GEAR 1 selected. Below the tabs, the "Gear 1" settings are displayed:

- Lock duty cycle at:  %
- For a duration of:  ms
- Enable if engine speed is greater than:  RPM
- Activate if engine speed drops by:  RPM

At the bottom of the window are "Done" and "Cancel" buttons.

Lock duty cycle at:  %

The **Lock duty cycle at** field sets the duty cycle that will be used while the gear change overboost control is activated.

For a duration of:  ms

The **For a duration of** field sets the amount of time that the gear change overboost control will be activated. Setting this threshold to zero will disable the gear change overboost control function in the corresponding gear.

Enable if engine speed is greater than:  RPM

The **Enable if RPM is greater than** field sets the RPM threshold over which the gear change overboost control can be activated. Setting this threshold to zero will disable the gear change overboost control function in the corresponding gear.

Activate if engine speed drops by:  RPM

The **Activate if engine speed drops by** field sets the amount RPM must drop by (in a single data sample) before the gear change overboost control will activate. If this field is set to zero the gear change overboost control will activate as soon as RPM reaches the **Enable if engine speed is greater than** threshold.

**WARNING:** Before attempting to use the closed-loop boost control settings, you should have a solid understanding of the material provided in this section.

Closed-loop boost control is a method where the controller uses feedback from the turbo system to determine the appropriate solenoid duty cycle needed to achieve the desired boost level. The controller continuously monitors intake manifold pressure and compares it to the target boost level. If there is a discrepancy, the controller adjusts the solenoid duty cycle to bring the manifold pressure in line with the target.

This method can enhance the controller's responsiveness and reduce boost fluctuations caused by changing environmental or driving conditions. This is accomplished by continuously making small adjustments on top of the baseline values set in the open-loop start duty cycle tables. While closed-loop control can theoretically reach a target boost level independently, relying solely on it is typically inefficient. Pneumatic boost control is a complex, variable process, and a closed-loop algorithm alone cannot reliably predict and control a turbo system's behavior.

Creating a baseline with the open-loop start duty cycle tables is essential for effective boost control. These tables should contribute most of the duty cycle applied to the BCS. If the closed-loop adjustments frequently exceed 5-10% to reach the target boost level, it indicates that the start duty cycle tables should be revised.

The feedback variable used in closed-loop boost control is known as "boost error." Boost error represents the difference between the target boost (the desired pressure for the turbo to produce) and the actual boost (the pressure currently being produced by the turbo). When the actual boost matches the target boost, the boost error is zero. If the actual boost is lower than the target boost, the boost error is positive. If the actual boost exceeds the target boost, the boost error is negative.

$$\text{Boost Error} = \text{Target Boost} - \text{Actual Boost}$$

CONDITION	BOOST ERROR
Boost is below target	$\text{Boost Error} > 0$
Boost matches target	$\text{Boost Error} = 0$
Boost is above target	$\text{Boost Error} < 0$

The closed-loop boost control function can employ up to three distinct feedback control algorithms, each contributing separately to the overall closed-loop duty cycle adjustment. When the closed-loop control function is active, the final duty cycle applied to the boost control solenoid (BCS) is determined using the following equation:

$$\text{Solenoid Duty Cycle} = (\text{Open-Loop Start Duty Cycle}) + (\text{Closed-Loop Duty Cycle Adjustment})$$

The closed-loop boost control function operates using a PID (Proportional-Integral-Derivative) control system, which combines three distinct feedback algorithms to generate a final control signal. Proportional control focuses on the instantaneous boost error at any given moment. Integral control considers the cumulative boost error over time, while derivative control responds to the rate of change of the boost error. Each algorithm outputs a duty cycle adjustment that can be positive or negative.

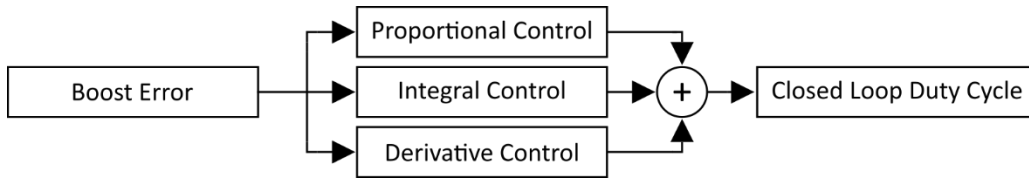

The behavior of each PID feedback algorithm is controlled by three key parameters:

- The first parameter, known as gain, determines how aggressively the algorithm adjusts duty cycle.
- The second parameter specifies the boost error threshold that must be reached before the algorithm becomes active.
- The third parameter limits the maximum duty cycle that the algorithm can contribute, both positively and negatively.

Additionally, two global parameters are used to restrict the total combined duty cycle contribution from all three feedback algorithms.

Closed-loop calculations are executed at the end of each on-off cycle of the boost control solenoid. For instance, if the solenoid pulses at 25 Hz, these calculations are performed 25 times per second.

---

#### CLOSED LOOP: PROPORTIONAL CONTROL ALGORITHM

The proportional control algorithm is the most straightforward of the feedback algorithms. Its output depends solely on the proportional gain, denoted as  $K_p$ , and the instantaneous boost error at the moment the closed-loop calculations are executed. The proportional duty cycle is determined using the following equation:

$$\text{Proportional Duty Cycle} = (\text{Instantaneous Boost Error}) \times K_p$$

When the actual boost is lower than the target boost, the proportional duty cycle will have a positive value to increase the boost level. Conversely, if the actual boost exceeds the target boost, the proportional duty cycle will be negative to reduce the boost level. If the actual boost matches the target boost, the proportional duty cycle will be zero.

CONDITION	DIRECT CONTROL OUTPUT
Boost is below target	Positive (+)
Boost matches target	Zero
Boost is above target	Negative (-)

The proportional duty cycle is directly linked to the magnitude of the boost error at the time of calculation. Larger boost errors will produce more significant duty cycle adjustments, while smaller errors will result in more modest adjustments.

TARGET BOOST	ACTUAL BOOST	BOOST ERROR	$K_p$	PROPORTIONAL DUTY CYCLE
10.0 PSI	2.0 PSI	<b>8.0 PSI</b>	2.0	$8.0 \times 2.0 = 16.0\%$
10.0 PSI	6.0 PSI	<b>4.0 PSI</b>	2.0	$4.0 \times 2.0 = 8.0\%$
10.0 PSI	10.0 PSI	<b>0.0 PSI</b>	2.0	$0.0 \times 2.0 = 0.0\%$
10.0 PSI	14.0 PSI	<b>-4.0 PSI</b>	2.0	$-4.0 \times 2.0 = -8.0\%$
10.0 PSI	18.0 PSI	<b>-8.0 PSI</b>	2.0	$-8.0 \times 2.0 = -16.0\%$

---

## CLOSED-LOOP: INTEGRAL CONTROL ALGORITHM

The integral control algorithm typically has the greatest impact on shaping the boost curve and, in many scenarios, it may be the only closed-loop algorithm necessary. Unlike the proportional control algorithm, which focuses solely on the current boost error, the integral control algorithm accounts for both the current boost error and the cumulative boost error from previous closed-loop calculations.

The output of the integral control algorithm is influenced by the integral gain parameter,  $K_I$ , and the total accumulation of boost error from prior calculations. The integral duty cycle is reset whenever the boost level drops to 0.0 PSI or when a gear change is detected. The integral duty cycle is calculated using the following equation (the  $\Sigma$  symbol means summation):

$$\text{Integral Duty Cycle} = \Sigma \left( \text{Instantaneous Boost Error} \times \frac{K_I}{\text{Solenoid Frequency}} \right)$$

If the actual boost is lower than the target boost, the integral duty cycle will increase to raise the boost level. Conversely, if the actual boost is higher than the target, the integral duty cycle will decrease to lower the boost. When the actual boost matches the target, the integral duty cycle remains steady, maintaining the current boost level.

For a simple illustration, assume a scenario where the boost error stays constant at 1.0 PSI, and the  $K_I$  value is set to 10.0. In this case, the integral duty cycle will accumulate to 10.0% after one second and continue to rise to 20.0% after two seconds. Similarly, if the boost error were -1.0 PSI, the integral duty cycle would decrease to -10.0% after one second and -20.0% after two seconds. While such scenarios are unlikely in real-world applications, they provide a clear understanding of how the integral control algorithm functions.

---

## CLOSED-LOOP: DERIVATIVE CONTROL ALGORITHM

The derivative control algorithm serves a different purpose compared to the proportional and integral algorithms. Rather than directly reducing boost error, it aims to limit the rate at which the boost error changes over time. This approach helps to smooth out rapid fluctuations in boost pressure. The output of the derivative control algorithm is determined by the derivative gain level,  $K_D$ , and the change in boost error measured since the last closed-loop calculation. The derivative duty cycle is calculated using the following equation:

$$\text{Derivative Duty Cycle} = \frac{[(\text{Instantaneous Boost Error}) - (\text{Previous Boost Error})] \times \text{Solenoid Frequency} \times K_D}{10}$$

The derivative control algorithm functions as a predictor of future boost errors and is particularly influential during transient boost conditions, such as when the turbocharger respools immediately after a gear change. Unlike the initial spooling from low RPM, turbochargers can achieve full boost much faster after a shift. In these scenarios, the derivative control algorithm helps manage this rapid boost climb by reducing the solenoid duty cycle, minimizing the risk of a boost spike.

CONDITION	DERIVATIVE DUTY CYCLE
Boost error is negative and boost is moving toward the target over time.	Positive (+)
Boost error is negative and boost is moving away from the target over time.	Negative (-)
Boost is constant.	Zero
Boost error is positive and boost is moving toward the target over time.	Negative (-)
Boost error is positive and boost is moving away from the target over time.	Positive (+)

## CLOSED-LOOP: TARGET BOOST

The closed-loop target boost tables define the desired boost level that the controller aims to achieve. Each open-loop start duty cycle setting has a corresponding closed-loop target boost value.

The screenshot shows the Cortex Config 6.3.5 Beta software interface. The main window displays the configuration for Profile 1, specifically the Target Boost table. The table lists target boost values in PSI for various gears and a Scramble state. The values are: Scramble (40.0), Gear 10 (0.0), Gear 9 (0.0), Gear 8 (35.0), Gear 7 (35.0), Gear 6 (35.0), Gear 5 (30.0), Gear 4 (20.0), Gear 3 (15.0), Gear 2 (10.0), and Gear 1 (10.0). The table is color-coded by gear level, with Scramble in yellow, Gear 10 in blue, Gear 9 in blue, Gear 8 in yellow, Gear 7 in yellow, Gear 6 in yellow, Gear 5 in green, Gear 4 in green, Gear 3 in cyan, Gear 2 in cyan, and Gear 1 in cyan.

	Target Boost (PSI)
Scramble	40.0
Gear 10	0.0
Gear 9	0.0
Gear 8	35.0
Gear 7	35.0
Gear 6	35.0
Gear 5	30.0
Gear 4	20.0
Gear 3	15.0
Gear 2	10.0
Gear 1	10.0

## CLOSED-LOOP: PID CONFIGURATION

The PID configuration parameters are used to configure the general behavior of the three closed-loop control algorithms.

PID Configuration - Profile 1

GEAR 1 GEAR 2 GEAR 3 GEAR 4 GEAR 5 GEAR 6 GEAR 7 GEAR 8 GEAR 9 GEAR 10 SCRAMBLE

**Gear 1**

**Proportional Control Algorithm**

Activate if boost error is less than: 0.0 PSI

Feedback gain: 0.0

Max duty cycle adjustment: 0.0 %

**Integral Control Algorithm**

Activate if boost error is less than: 0.0 PSI

Feedback gain: 0.0

Max duty cycle adjustment: 0.0 %

**Derivative Control Algorithm**

Activate if boost error is less than: 0.0 PSI

Feedback gain: 0.0

Max duty cycle adjustment: 0.0 %

**Combined Control Limits**

Max (+) combined adjustment: 0.0 %

Max (-) combined adjustment: 0.0 %

Done Cancel

Activate if boost error is less than: 0.0 PSI

The **Activate if boost error is less than** field sets the boost error threshold under which the corresponding control algorithm will be activated. Boost error is defined as target boost minus actual boost.

For example, if target boost is set to 18.0 PSI and the **Activate if boost error is less than** parameter is set to 2.0 PSI then the corresponding control algorithm will be disabled until boost reaches 16.0 PSI.

Setting this parameter to zero will allow the corresponding control algorithm to activate as soon as boost is greater than 0.0 PSI.

Feedback gain: 0.0

The **Feedback gain** field sets the aggressiveness of the duty cycle adjustments made by the corresponding control algorithm. Setting this parameter to zero will disable the corresponding closed-loop boost control algorithm.

Max duty cycle adjustment: 0.0 %

The **Max duty cycle adjustment** field sets the maximum duty cycle contribution (+/-) of the corresponding control algorithm. Setting this parameter to zero will disable the corresponding closed-loop boost control algorithm.

Max (+) combined adjustment: 0.0 %

Max (-) combined adjustment: 0.0 %

The **Max (+) combined adjustment** and **Max (-) combined adjustment** fields set the maximum combined duty cycle contribution from all three control algorithms. Separate limits are provided for positive and negative duty cycle adjustments. Setting the (+) parameter to zero will prevent the closed-loop boost control from making positive duty cycle adjustments. Setting the (-) parameter to zero will prevent the closed-loop boost control from making negative duty cycle adjustments. Setting both parameters to zero will completely disable the closed-loop boost control.

### CONFIGURATION EXAMPLE – Recommended initial settings for 3-Port BCS

PID Configuration - Profile 1

GEAR 1 GEAR 2 GEAR 3 GEAR 4 GEAR 5 GEAR 6 GEAR 7 GEAR 8 GEAR 9 GEAR 10 SCRAMBLE

**Gear 1**

Proportional Control Algorithm	Integral Control Algorithm	Derivative Control Algorithm
Activate if boost error is less than: 2.0 PSI	Activate if boost error is less than: 2.0 PSI	Activate if boost error is less than: 5.0 PSI
Feedback gain: 1.0	Feedback gain: 5.0	Feedback gain: 2.0
Max duty cycle adjustment: 5.0 %	Max duty cycle adjustment: 10.0 %	Max duty cycle adjustment: 10.0 %

**Combined Control Limits**

Max (+) combined adjustment: 10.0 %
Max (-) combined adjustment: 10.0 %

Done Cancel

### CONFIGURATION EXAMPLE – Recommended initial settings for 4-Port BCS

PID Configuration - Profile 1

GEAR 1 GEAR 2 GEAR 3 GEAR 4 GEAR 5 GEAR 6 GEAR 7 GEAR 8 GEAR 9 GEAR 10 SCRAMBLE

**Gear 1**

Proportional Control Algorithm	Integral Control Algorithm	Derivative Control Algorithm
Activate if boost error is less than: 2.0 PSI	Activate if boost error is less than: 2.0 PSI	Activate if boost error is less than: 5.0 PSI
Feedback gain: 0.5	Feedback gain: 5.0	Feedback gain: 2.0
Max duty cycle adjustment: 2.0 %	Max duty cycle adjustment: 5.0 %	Max duty cycle adjustment: 5.0 %

**Combined Control Limits**

Max (+) combined adjustment: 5.0 %
Max (-) combined adjustment: 5.0 %

Done Cancel

## LAUNCH

The launch boost control function temporarily overrides normal boost control while the vehicle is staged for a launch. This function can be activated based on specific sensor inputs, such as vehicle speed, RPM, or throttle position, or through an external button connected to the Cortex EBC wiring harness.

For the launch boost control function to significantly impact pre-launch boost levels, the vehicle must be equipped with a 2-step rev limiter. In many cases, achieving substantial boost levels before launch also requires adjustments to engine timing and fueling through the ECU/ECM/PCM (anti-lag settings).

The screenshot shows the 'Launch Boost Control - Profile 1' dialog box with the 'Activation Criteria' tab selected. The 'Activation method' is set to 'Sensors'. The settings are: 'Activate until speed is greater than: 0 MPH', 'Do not activate if engine speed is less than: 0 RPM', and 'Do not activate if throttle is less than: 0.0 % Open'. 'Done' and 'Cancel' buttons are at the bottom.

The screenshot shows the 'Launch Boost Control - Profile 1' dialog box with the 'Open-Loop' tab selected. The settings are: 'Lock duty cycle at: 0.0 %', 'Until boost is greater than: 0.0 PSI', and 'Then use start duty cycle of: 0.0 %'. 'Done' and 'Cancel' buttons are at the bottom.

The screenshot shows the 'Launch Boost Control - Profile 1' dialog box with the 'Closed-Loop' tab selected. The settings are: 'Activate if boost is greater than: 0.0 PSI', 'Target boost: 0.0 PSI', 'Integral feedback gain: 0.0', and 'Max duty cycle adjustment: 0.0 %'. 'Done' and 'Cancel' buttons are at the bottom.

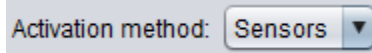
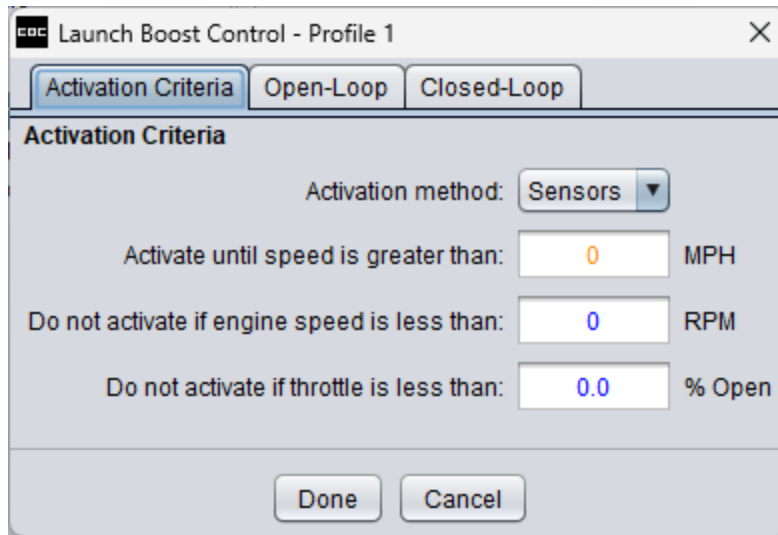

The **Activation method** field determines whether launch boost control will be activated based on sensor readings (MPH, RPM, TPS) or activated based on a button press.

- **Sensors** – Launch boost control will be activated until vehicle speed reaches a specified MPH. Additional RPM and/or TPS activation criteria can be optionally used. The speed input must be properly calibrated to provide accurate MPH readings when using this activation method.
- **Button** – Launch boost control will be activated when the transbrake button is pressed.

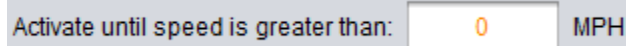

The **Activate until speed is greater than** field sets the MPH threshold under which the launch boost control will be activated. Setting the threshold to zero will disable the launch boost control function.

**NOTE:** The speed input must be properly calibrated to provide accurate MPH readings when using this parameter.

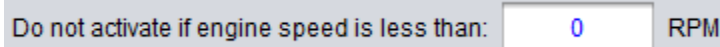

The **Do not activate if engine speed is less than** field sets the RPM threshold over which the launch boost control can activate. If this threshold is set to zero it will be ignored by the launch boost control activation logic.

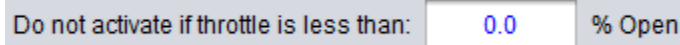

The **Do not activate if throttle is less than** field sets the throttle position threshold over which the launch boost control can activate. If this threshold is set to zero it will be ignored by the launch boost control activation logic.

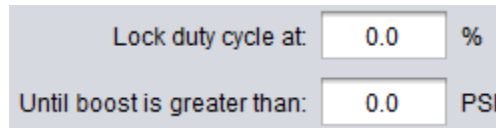
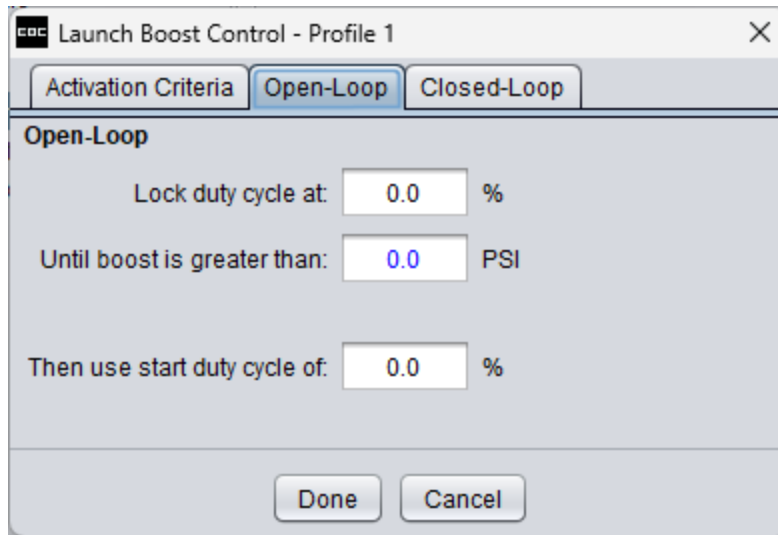

The **Lock duty cycle at** and **Until boost is greater than** fields are used to configure the initial boost control stage.

**Lock duty cycle at** – Sets the constant duty cycle that will be used while the initial boost control stage is enabled (typically 100%).

**Until boost is greater than** – Sets the threshold above which the initial boost control stage will be disabled and the primary boost control stage will be enabled. Set to a value that is a few PSI below the final target boost level. Setting this threshold to zero will cause the initial boost control stage to be skipped.

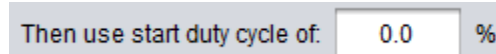

The **Then use start duty cycle of** field sets the start duty cycle value that will be used while the primary boost control stage is enabled. Using the process of trial and error, this parameter should be set to the value that gets you as close to target boost as possible without any additional closed-loop adjustments.

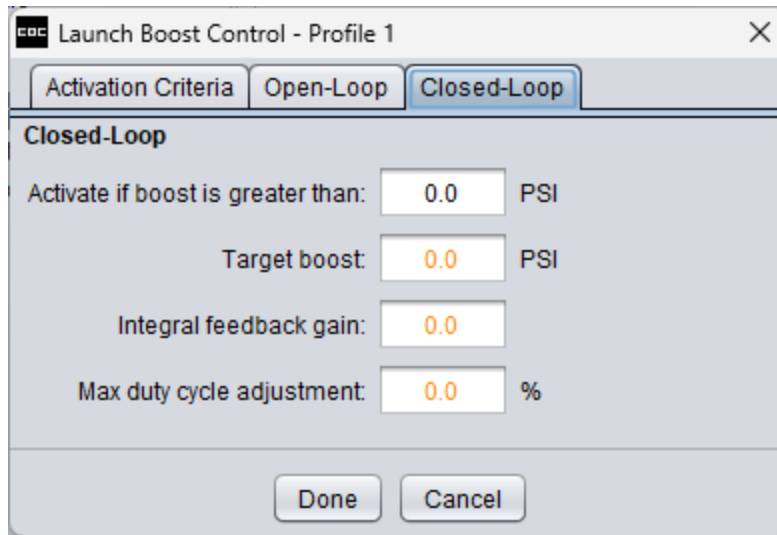

Activate if boost is greater than:  PSI

The **Activate if boost is greater than** field sets the boost threshold over which the closed-loop control algorithm will be activated in the primary boost control stage.

Target boost:  PSI

The **Target boost** field sets the boost level that the closed-loop control algorithm will try to achieve and maintain while the launch boost control function is activated. Setting this field to zero will disable the closed-loop control.

Integral feedback gain:

The **Integral feedback gain** field sets the aggressiveness of the duty cycle adjustments made by the closed-loop control algorithm. Setting this field to zero will disable the closed-loop control.

Max duty cycle adjustment:  %

The **Max duty cycle adjustment** field sets the maximum duty cycle contribution (+/-) of the closed-loop control algorithm. Setting this field to zero will disable the closed-loop control.

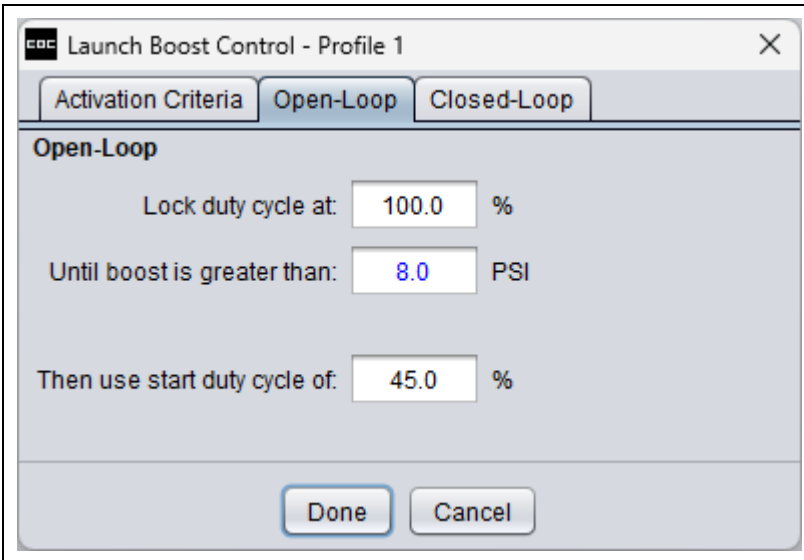

**OPEN-LOOP CONFIGURATION EXAMPLE:**

When the launch boost control function is activated, the duty cycle is set to 100% until the boost reaches 8.0 PSI. Once this threshold is reached, the duty cycle drops to 45% and stays at that level unless the closed-loop control is activated.

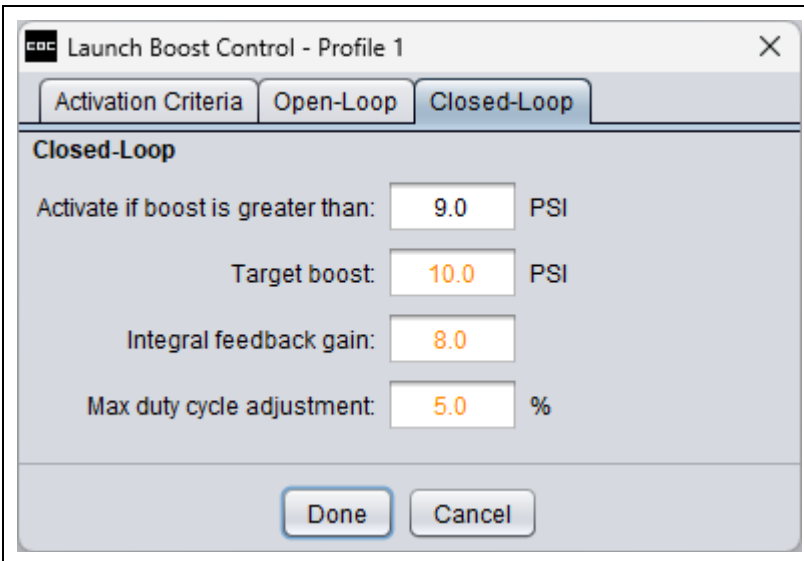

**CLOSED-LOOP CONFIGURATION EXAMPLE:**

The closed-loop control function activates when the boost reaches 9.0 PSI. At this point, the algorithm targets 10.0 PSI and can adjust the duty cycle by up to 5% in either direction. Based on the open-loop settings above, this allows the duty cycle to range between 40% and 50% to maintain the 10.0 PSI target.

## FAIL-SAFES

The Cortex EBC includes three distinct fail-safe functions designed to disable boost control and help protect the engine from potential damage. These fail-safes can be triggered by excessive boost levels or abnormal readings from a sensor connected to the general-purpose input (GPI). When a fail-safe condition is detected, the system will immediately set the solenoid duty cycle to 0.0% to disable boost control. Additionally, the 7-segment LED display will flash, and the controller's internal audio buzzer will emit a continuous beep.

### FAIL-SAFES: OVERBOOST

The overboost fail-safe is designed to disable boost control when an excessive boost condition occurs. This fail-safe activates whenever the boost pressure exceeds the specified activation threshold. It remains active until the boost pressure drops back below the threshold.

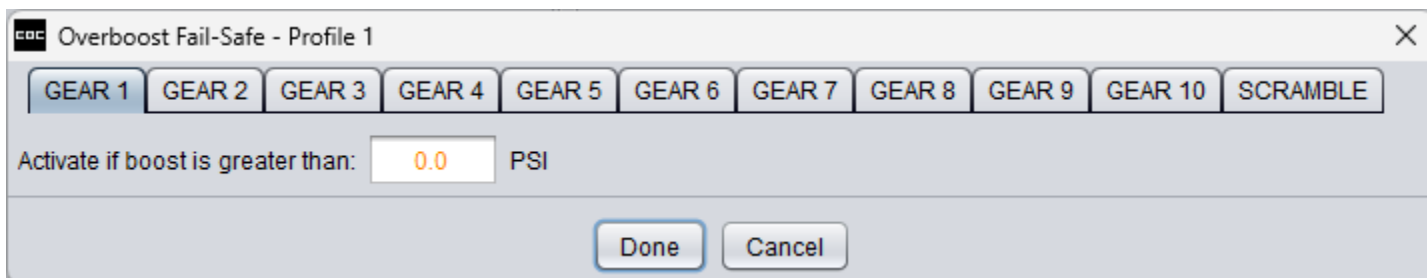

Activate if boost is greater than:  PSI

The **Activate if boost is greater than** field sets the boost threshold over which the overboost fail-safe will activate and disable boost control. Setting this threshold to zero will disable the overboost fail-safe in the corresponding gear.

**WARNING:** It is possible for boost to continue to spike by several PSI after the overboost fail-safe activates if boost is climbing rapidly when the activation threshold is reached.

---

## FAIL-SAFES: GPI GENERAL

The GPI general fail-safe can be used to disable boost control based on readings from an analog or digital sensor that is connected to the general-purpose input. Possible applications include air-fuel ratio, fuel pressure, turbo speed, water/methanol pressure or flow, and ethanol content.

The GPI general fail-safe can be configured to activate if the sensor output is below a specified value, above a specified value, or outside a specified range of values (below value 1 or above value 2). A delay period can be added to prevent unwanted fail-safe activation from erroneous readings. This fail-safe will remain activated until the throttle is closed and boost drops back to 0 PSI.

**NOTE:** The general-purpose input must be properly configured to obtain accurate readings from your sensor for this fail-safe to function as expected. See [this section](#) to learn more about configuring the general-purpose input.

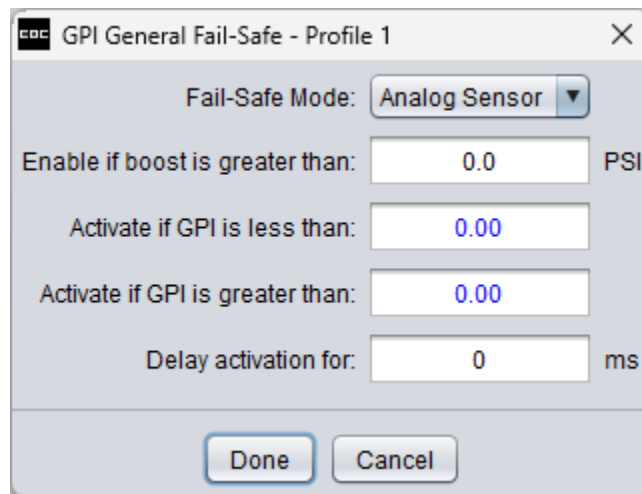

The screenshot shows a dialog box titled "GPI General Fail-Safe - Profile 1" with a close button (X) in the top right corner. The dialog contains the following configuration options:

- Fail-Safe Mode:** A dropdown menu set to "Analog Sensor".
- Enable if boost is greater than:** A text input field containing "0.0" with "PSI" to its right.
- Activate if GPI is less than:** A text input field containing "0.00".
- Activate if GPI is greater than:** A text input field containing "0.00".
- Delay activation for:** A text input field containing "0" with "ms" to its right.

At the bottom of the dialog are two buttons: "Done" and "Cancel".

Fail-Safe Mode:

The **Fail-safe mode** field sets the operating mode for the GPI general fail-safe.

- **Disabled** – fail-safe is not used
- **Analog Sensor** – fail-safe is used with analog sensor
- **Digital Sensor** – fail-safe is used with digital sensor

Enable if boost is greater than:  PSI

The **Enable if boost is greater than** field sets the boost threshold over which the GPI general fail-safe can be activated. The fail-safe will be able to activate at any time the engine is in boost if the threshold is left at 0.0 PSI.

Activate if GPI is less than:

Activate if GPI is greater than:

The **Activate if GPI is less than** and **Activate if GPI is greater than** fields set the sensor output thresholds under and/or over which the fail-safe will activate and disable boost control. If a threshold is set to zero it will be ignored by the fail-safe activation logic. Threshold resolution is 0.01 for analog sensors and 1 for digital sensors.

**NOTE:** These fields should be set to the actual sensor value that is calculated by the Cortex EBC (not the raw volts or Hz value).

Delay activation for:  ms

The **Delay activation for** field sets the number of milliseconds that the sensor readings must be continuously out of the acceptable range before the GPI general fail-safe will activate. The use of this parameter is completely optional, but it is recommended for most applications. A delay of 100 ms is sufficient in most cases.

GPI General Fail-Safe - Profile 1

Fail-safe mode: Analog Sensor

Enable if boost is greater than: 5.0 PSI

Activate if GPI is less than: 0.00

Activate if GPI is greater than: 12.00

Delay activation for: 200 ms

Done Cancel

**AIR-FUEL RATIO (AFR) FAIL-SAFE EXAMPLE**

Activate fail-safe if boost is greater than 5.0 PSI and AFR is leaner than 12.0 for 200 milliseconds.

GPI General Fail-Safe - Profile 1

Fail-safe mode: Digital Sensor

Enable if boost is greater than: 5.0 PSI

Activate if GPI is less than: 85

Activate if GPI is greater than: 0

Delay activation for: 200 ms

Done Cancel

**ETHANOL CONTENT FAIL-SAFE EXAMPLE**

Activate fail-safe if boost is greater than 5.0 PSI and ethanol content is less than 85% for 200 milliseconds.

GPI General Fail-Safe - Profile 1

Fail-safe mode: Analog Sensor

Enable if boost is greater than: 5.0 PSI

Activate if GPI is less than: 100.00

Activate if GPI is greater than: 220.00

Delay activation for: 200 ms

Done Cancel

**WATER/METHANOL PRESSURE FAIL-SAFE EXAMPLE**

Activate fail-safe if boost is greater than 5.0 PSI and water/methanol pressure is less than 100 PSI for 200 milliseconds or greater than 220 PSI for 200 milliseconds.

FAIL-SAFES: GPI WATER/METHANOL

The GPI water/methanol fail-safe offers advanced protection against water/methanol injection (WMI) system failures by allowing users to define acceptable operational ranges for the system. These ranges can be configured at up to 11 different points, based on the WMI pump or solenoid duty cycle. If system pressure or flow deviates from these acceptable ranges, the fail-safe will activate, disabling boost control to protect the engine. This fail-safe can engage at any boost level above 0 PSI and will remain active until the throttle is closed and boost pressure returns to 0 PSI

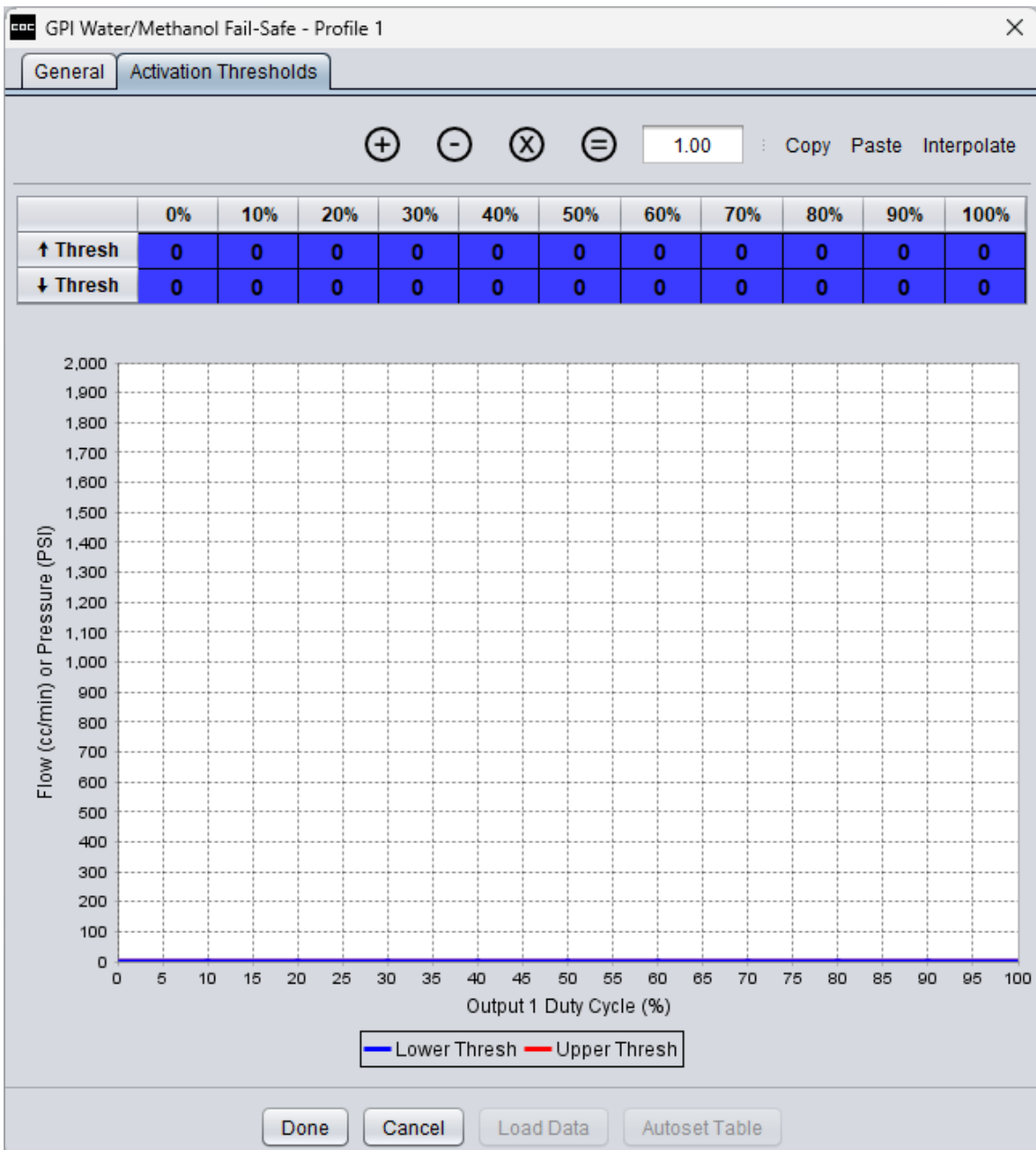
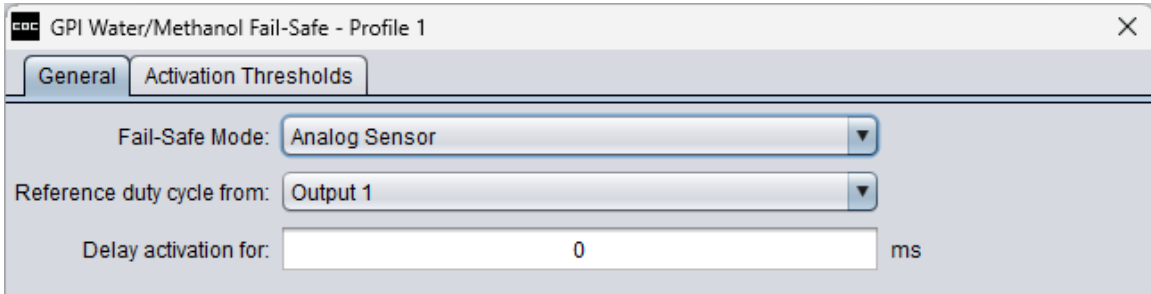

Fail-Safe Mode:

The **Fail-safe mode** field sets the operational mode for the GPI water/methanol fail-safe.

- **Disabled** – fail-safe is not used
- **Analog Sensor** – fail-safe is used with analog sensor (pressure)
- **Digital Sensor** – fail-safe is used with digital sensor (flow)

Reference duty cycle from:

The **Reference duty cycle from** field sets the auxiliary output that the fail-safe will reference duty cycle from. Set to match the Cortex EBC output (1 or 2) that provides PWM control to your WMI pump or high-speed WMI solenoid.

Delay activation for:  ms

The **Delay activation for** field sets the number of milliseconds that the WMI pressure or flow readings must be continuously out of the acceptable range before the GPI water/methanol fail-safe will activate. The use of this parameter is completely optional, but it is recommended for most applications. A delay of 100 ms is sufficient in most cases.

	0%	10%	20%	30%	40%	50%	60%	70%	80%	90%	100%
↑ Thresh	0	0	0	0	0	0	0	0	0	0	0
↓ Thresh	0	0	0	0	0	0	0	0	0	0	0

The table in the Activation Thresholds tab of the GPI Water/Methanol Configuration window is used to set the upper and lower thresholds for acceptable pressure/flow.

## ADDITIONAL NOTES FOR BOOST BY RPM

A boost by RPM control strategy is typically used to reduce boost fluctuations caused by increasing engine speeds, to reduce boost at high engine speeds because of fuel system limitations, or to reduce boost (and therefore torque) at low engine speeds to prevent engine damage. Boost by RPM is most effective when it is set on a gear-by-gear basis (boost-by-RPM per gear).

### General open-loop tuning procedure to flatten boost curve:

1. Set all cells in the start duty cycle table to 20%.
2. Gradually increase the start duty cycle uniformly across all table cells until the peak boost level matches your target boost level.
3. Increase the start duty cycle specifically in the cells where the actual boost is still below the target boost level.
4. Continue adjusting the start duty cycle in the relevant cells until you achieve a flat boost curve. As you progress, the number of cells requiring modifications should decrease, indicating you're on the right track.

## ADDITIONAL NOTES FOR BOOST BY SPEED

In most cases, gear detection should be disabled when using a speed-based boost control strategy. This is because each gear only covers a limited range of speeds, meaning only a small portion of the table cells are used in each gear. Disabling gear detection causes the controller to default to the 1st gear settings, allowing you to use a single start duty cycle and target boost table instead of dividing adjustments across multiple small table segments.

To disable gear detection, set all EVS ratio values in the vehicle configuration file to zero.

## ADDITIONAL NOTES FOR BOOST BY TIME

The gear detection will be automatically disabled when using a time-based boost control strategy.

The launch boost control function must be used to activate the time-based control sequence.

The controller will continue to use the final start duty cycle and target boost table cells once the end of the time-based sequence has been reached. However, the boost control solenoid will automatically be disabled after 20 seconds.

## ADDITIONAL NOTES FOR COMPRESSED AIR BOOST CONTROL

When using compressed air for boost control, the maximum boost level is determined by the setting of your air regulator. For instance, if the regulator is set to 20 PSI, you can put 20 PSI of pressure "on the dome" at 100% duty cycle. Ideally, this would result in a boost level 20 PSI higher than the spring pressure. In practice, however, the actual boost level will be lower than this.

## AUXILIARY OUTPUTS

The Cortex EBC provides two programmable outputs capable of controlling various devices using either basic on/off operation or progressive PWM control. The outputs can be activated based on boost pressure, engine speed, vehicle speed, general-purpose input, and gear. The outputs can be configured to activate if a parameter is above a specified value, below a specified value, or within a specified range of values (above value 1 and below value 2). If multiple parameters are included in the activation criteria, then all parameters must be within their valid activation ranges for the output to activate.

Two optional time limitations can be used to limit the amount of time that an output can be activated. The first limiter defines the maximum continuous activation time once the criteria are met. For instance, this can deliver a 1-second pulse for an air shifter. The second limiter sets the cumulative activation time within a defined interval, which is useful for devices like intercooler or radiator sprayers—e.g., limiting spray to 1 minute within a 5-minute window.

Additionally, each output includes an alternative function mode for specific applications. The alternate mode for output 1 enables transbrake bump control. For output 2, the alternate mode links it to output 1, causing output 2 to activate at 100% duty cycle (fully on) whenever the output 1 duty cycle is greater than zero.

**See [this section](#) for information on auxiliary output wiring.**

**See [this section](#) to learn how to enable the auxiliary outputs.**

PRIMARY OUTPUT ACTIVATION CRITERIA

<p><b>Boost Activation</b></p> <p>Boost activation logic mode: <input type="button" value="Enabled"/> ▾</p> <p>Activate if boost is greater than or equal to: <input type="text" value="0.0"/> PSI</p> <p>Deactivate if boost is greater than or equal to: <input type="text" value="0.0"/> PSI</p>	<p><b>RPM Activation</b></p> <p>RPM activation logic mode: <input type="button" value="Enabled"/> ▾</p> <p>Activate if RPM is greater than or equal to: <input type="text" value="0"/> RPM</p> <p>Deactivate if RPM is greater than or equal to: <input type="text" value="0"/> RPM</p>
<p><b>GPI Activation</b></p> <p>GPI activation logic mode: <input type="button" value="Analog"/> ▾</p> <p>Activate if GPI is greater than or equal to: <input type="text" value="0.00"/></p> <p>Deactivate if GPI is greater than or equal to: <input type="text" value="0.00"/></p>	<p><b>MPH Activation</b></p> <p>MPH activation logic mode: <input type="button" value="Enabled"/> ▾</p> <p>Activate if MPH is greater than or equal to: <input type="text" value="0"/> MPH</p> <p>Deactivate if MPH is greater than or equal to: <input type="text" value="0"/> MPH</p>

Boost activation logic mode:  ▾

The **Boost activation logic mode** field is used to determine if boost information is included in the activation logic for the corresponding output.

- **Disabled** – Do not include boost in output activation logic.

**Enabled** – Include boost in output activation logic.

---

Activate if boost is greater than or equal to:  PSI  
 Deactivate if boost is greater than or equal to:  PSI

The **Activate if boost is greater than or equal to** and **Deactivate if boost is greater than or equal to** fields set the boost thresholds over and/or under which the corresponding output can be activated. If the **Deactivate if boost is greater than or equal to** threshold is set to zero it will be ignored by the output activation logic. If both thresholds are set to zero it will allow the output to activate at any boost level.

RPM activation logic mode:  ▾

The **RPM activation logic mode** field is used to determine if engine speed information is included in the activation logic for the corresponding output.

- **Disabled** – Do not include engine speed in output activation logic.

**Enabled** – Include engine speed in output activation logic.

---

Activate if RPM is greater than or equal to:  RPM  
 Deactivate if RPM is greater than or equal to:  RPM

The **Activate if RPM is greater than or equal to** and **Deactivate if RPM is greater than or equal to** fields set the RPM thresholds over and/or under which the corresponding output can be activated. If the **Deactivate if RPM is greater than or equal to** threshold is set to zero it will be ignored by the output activation logic. If both thresholds are set to zero it will allow the output to activate at any engine speed.

GPI activation logic mode: Disabled ▼

The **GPI activation logic mode** field is used to determine if general-purpose input (GPI) information is included in the activation logic for the corresponding output.

- **Disabled** – Do not include GPI in output activation logic.
- **Analog** – Include GPI information from analog sensor in output activation logic.

**Digital** – Include GPI information from digital sensor in output activation logic.

Activate if GPI is greater than or equal to: 0.00

Deactivate if GPI is greater than or equal to: 0.00

The **Activate if GPI is greater than or equal to** and **Deactivate if GPI is greater than or equal to** fields set the GPI thresholds over and/or under which the corresponding output can be activated. If the **Deactivate if GPI is greater than or equal to** threshold is set to zero it will be ignored by the output activation logic. If both thresholds are set to zero it will allow the output to activate at any sensor level. Threshold resolution is 0.01 for analog sensors and 1 for digital sensors.

**NOTE:** These fields should be set to the actual sensor value that is calculated by the Cortex EBC (not the raw volts or Hz value).

MPH activation logic mode: Disabled ▼

The **MPH activation logic mode** field is used to determine if speed information is included in the activation logic for the corresponding output.

- **Disabled** – Do not include speed in output activation logic.

**Enabled** – Include speed in output activation logic.

Activate if MPH is greater than or equal to: 0 MPH

Deactivate if MPH is greater than or equal to: 0 MPH

The **Activate if MPH is greater than or equal to** and **Deactivate if MPH is greater than or equal to** fields set the MPH thresholds over and/or under which the corresponding output can be activated. If the **Deactivate if MPH is greater than or equal to** threshold is set to zero it will be ignored by the output activation logic. If both thresholds are set to zero it will allow the output to activate at any speed.

Gear Activation	Activation Time Limits
Activate in gear 1: <input type="checkbox"/>	Activate in gear 6: <input type="checkbox"/>
Activate in gear 2: <input type="checkbox"/>	Activate in gear 7: <input type="checkbox"/>
Activate in gear 3: <input type="checkbox"/>	Activate in gear 8: <input type="checkbox"/>
Activate in gear 4: <input type="checkbox"/>	Activate in gear 9: <input type="checkbox"/>
Activate in gear 5: <input type="checkbox"/>	Activate in gear 10: <input type="checkbox"/>
	Activate in scramble: <input type="checkbox"/>
	Time activation limit mode: <span>Both ▾</span>
	Limit single activation time to: <span>0</span> s
	Limit total activation time to: <span>0</span> s
	Reset total activation count every: <span>0</span> min

Activate in gear 1:

The **Activate in gear X** field is used to determine which gears the corresponding output can activate in.

- **Unselected** – Output cannot activate in the corresponding gear.
- **Selected** – Output can activate in the corresponding gear.

**NOTE:** If the gear detection is not configured the **Activate in gear 1** box must still be checked or the output will never activate.

Time activation limit mode: Disabled ▾

The **Time activation limit mode** field sets the operating mode for the time-based activation limit function.

- **Disabled** – No limit on the amount of time that the corresponding output can be activated.
- **Single** – Limit the duration of a single activation on the corresponding output.
- **Total** – Limit the total amount of time that the corresponding output can be activated during a specified number of minutes.
- **Both** – Limit both the single activation time and total activation time on the corresponding output.

Limit single activation time to: 0 s

The **Limit single activation time to** field sets the total number of seconds that a single output activation event can last for. If the single activation time limit is utilized, then setting this parameter to zero will completely disable the corresponding output.

Limit total activation time to: 0 s  
Reset total activation count every: 0 min

The **Limit total activation time to** and **Reset total activation count every** fields determine the limits on the total amount of time the output can be activated for. The **Limit total activation time to** parameter sets the maximum number of seconds that the output can be activated for. This count will be paused while the output is not activated and resumed whenever the output is activated. The count will be reset to zero each time the number of minutes defined by the **Reset total activation count every** parameter has passed. If the total activation time limit is utilized, then setting either of these parameters to zero will completely disable the corresponding output.

---

## ALTERNATE OUTPUT FUNCTIONS

**Output 1 Alternate Function**

Transbrake bump control mode:

Interrupt transbrake for:  ms

Transbrake bump control mode:

The **Transbrake bump control mode** field sets the operating mode for the transbrake bump control function available on output 1.

- **Disabled** – Transbrake bump control is disabled and output 1 will operate normally.
- **Enabled** – Transbrake bump control is enabled and output 1 will function as a bump box.

Interrupt transbrake for:  ms

The **Interrupt transbrake for** field sets the number of milliseconds that the transbrake will be interrupted for each time the bump button is pressed. Setting this parameter to zero will prevent the transbrake bump control function from operating.

**NOTE:** Most solenoids will require a minimum interrupt time of 5-20 milliseconds before they will begin to release.

**Output 2 Alternate Function**

Output 1 follower mode:

Output 1 follower mode:

The **Output 1 follower mode** field sets the operating mode for the output 1 follower function available on output 2.

- **Disabled** – Output 1 follower is disabled and output 2 will operate normally.
- **Enabled** – Output 1 follower is enabled and output 2 will be set to 100% duty cycle whenever output 1 is activated.

---

## PWM CONFIGURATION

**PWM Frequency Settings**

PWM Frequency:  Hz

PWM frequency:  Hz

The **PWM frequency** field sets the frequency for the PWM signal produced on both outputs. This parameter should be set to an appropriate frequency for the devices being controlled by the outputs. To utilize progressive control on both outputs the devices connected to the outputs must be able to operate at the same PWM frequency.

### Output 1 Progressive Settings

Output control strategy:	2D Linear Ramp	X-axis reference:	RPM
2D ramp reference:	RPM	X-axis min value:	0
Initial duty cycle:	0 %	X-axis step size:	0
Final duty cycle:	0 %	Y-axis reference:	RPM
Ramp duty cycle at:	0 %	Y-axis min value:	0
Per:	0	Y-axis step size:	0

Output control strategy: On/Off

The **Output control strategy** field sets the general method of progressive control that will be used by the corresponding output.

- **On/Off** – Progressive control is disabled. The output will simply turn on and off based on the activation criteria.
- **2D Linear Ramp** – Progressive control is enabled. When the activation criteria are met the output duty cycle will be linearly ramped between two control points.
- **3D Table** – Progressive control is enabled. When the activation criteria are met the output duty cycle will be determined by a 16 x 24 cell 3D table.

2D ramp reference: RPM

The **2D ramp reference** field sets the type of data that will be referenced for progressive control by the 2D Linear Ramp control strategy. Possible data types are RPM, Speed, GPI (General-Purpose Input), Boost, or Time.

**NOTE:** If the **2D ramp reference** is set to RPM, Speed, GPI, or Boost this parameter must also be included in the activation criteria for the corresponding output.

Start duty cycle:	0	%
Final duty cycle:	0	%

The **Initial duty cycle** and **Final duty cycle** field sets the minimum and maximum duty cycles that can be generated on the corresponding output by the 2D Linear Ramp control strategy. Both increasing and decreasing ramps are supported. If the duty cycle ramp is referenced to RPM, speed, GPI, or boost then the **Initial duty cycle** will be applied at the activation threshold for the referenced parameter.

Ramp duty cycle at:	0	%
Per:	0	

The **Ramp duty cycle at** and **Per** fields set the rate at which duty cycle will be ramped up or down by the 2D Linear Ramp control strategy. For example, if the duty cycle is referenced to boost, and the **Ramp duty cycle at** and **Per** parameters are both set to 1, then the output duty cycle will be change at a rate of 1% per 1 PSI change in boost.

X-axis reference: RPM

The **X-axis reference** field sets the type of data that will be referenced by the x-axis of the 3D output control tables. Possible data types are RPM, Speed, GPI (General-Purpose Input), and Boost.

X-axis min value: 0

X-axis step size: 0

The **X-axis min value** and **X-axis step size** fields determine the scaling of the 16 control points on the x-axis of the 3D output control tables. The first parameter sets the value of the initial control point, and the second parameter sets the spacing between all the subsequent control points. The first and last control points will continue to be used for output control in situations that are outside of the axis bounds.

Y-axis reference: RPM

The **Y-axis reference** field sets the type of data that will be referenced by the y-axis of the 3D output control tables. Possible data types are RPM, Speed, GPI (General-Purpose Input), and Boost.

Y-axis min value: 0

Y-axis step size: 0

The **Y-axis min value** and **Y-axis step size** fields determine the scaling of the 24 control points on the y-axis of the 3D output control tables. The first parameter sets the value of the initial control point, and the second parameter sets the spacing between all the subsequent control points. The first and last control points will continue to be used for output control in situations that are outside of the axis bounds.